

ROBE

Robin iESPRITE® LTL WB

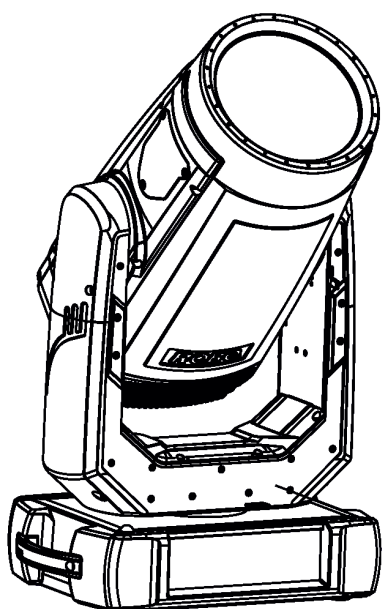

Robin iESPRITE® LTL FS

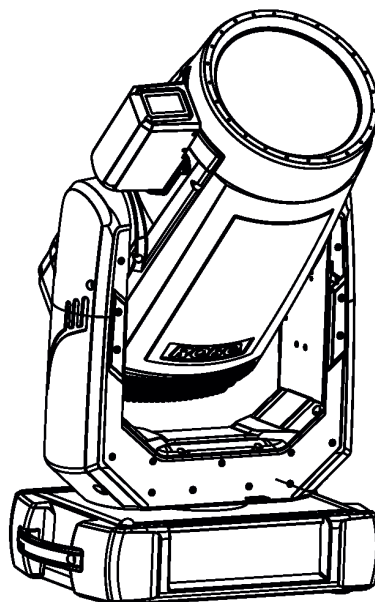

QR code for user manual



USER MANUAL

ROBE® lighting s.r.o. • Czech Republic • www.robe.cz

Version 1.3

Robin iEsprite LTL WB

Robin iEsprite LTL FS

Table of contents

1. Safety instructions and operating determinations	3
2. Fixture exterior view	6
3. Installation	7
3.1 Connection to the mains	7
3.2 Installing removable handles	8
3.3 Replacing the frost	9
3.5 Replacing static gobos	13
3.6 Camera installation	14
3.7 Rigging the fixture	15
3.8 DMX-512 connection	18
3.9 Ethernet connection	19
3.10 Wireless DMX operation	21
4. Checking the IP65 integrity of the fixture	22
5. Operating the fixture at ambient temperatures below 0°C	24
6. Standby mode	25
7. Remotely controllable functions	26
7.1 Long throw mode	28
8. Control menu map	29
9. Control menu	33
9.1 Tab "Address"	36
9.2 Tab "Information"	36
9.3 Tab "Personality"	40
9.4 Tab "Manual Control"	42
9.5 Tab "Stand-alone"	43
9.6 Tab "Service"	43
10. RDM	48
11. Error and information messages	49
12. NFC	53
13. Cleaning	53
14. Maintenance	54
14.1 Fixture watertight covers and torques of covers screws	56
14.2 Torques of Pan/Tilt motors screws	59
14.3 Changing the LED light source	60
14.4 Checking and replacing the silica gel desiccants	64
14.5 Disposing of the product	66
15. Obtaining information about the LED light source by mobile phone	67
16. Robe Ethernet Access Portal (REAP)	69
17. Technical Specifications	77
18. ChangeLog	82

**FOR YOUR OWN SAFETY, PLEASE READ THIS USER MANUAL CAREFULLY
BEFORE YOU INITIAL START - UP**

This device has left our premises in absolutely perfect condition. In order to maintain this condition and to ensure a safe operation, it is absolutely necessary for the user to follow the safety instructions and warnings in this manual.

The manufacturer will not accept liability for any resulting damages caused by the non-observance of this manual or any unauthorized modification to the device.

Please consider that damages caused by manual modifications to the device are not subject to warranty.

The Robin iEsprite LTL was designed for outdoor use and it is intended for professional application only. It is not for household use.

1. Safety instructions and operating determinations

CAUTION!

Disconnect the fixture from mains before removing any cover of the fixture. With a high voltage you can suffer a dangerous electric shock when touching alive wires and electrical parts under covers!

Make sure that the available voltage is not higher than stated on the rear panel of the fixture. This fixture should be operated only from the type of power source indicated on the marking label. If you are not sure of the type of power supplied, consult your authorized distributor or local power company.

Always disconnect the fixture from AC power before cleaning, removing or servicing any part of the fixture.

The power plug has to be accessible after installing the fixture. Do not overload wall outlets and extension cords as this can result in fire or electric shock.

Do not allow anything to rest on the power cord. Do not locate this fixture where the cord may be damaged by persons walking on it.

Make sure that the power cord is never crimped or damaged by sharp edges. Check the fixture and the power cord from time to time.

Refer servicing to qualified service personnel.

This fixture falls under protection class I. Therefore this fixture has to be connected to a mains socket outlet with a protective earthing connection.

Do not connect this fixture to a dimmer pack.

During the initial start-up some smoke or smell may arise. This is a normal process and does not necessarily mean that the device is defective.

Do not focus the fixture beam onto flammable surfaces. The minimum distance between the front lens of the device and the illuminated surface must be greater than 3 meters.

***LED light emission. Risk of eye injury.
Do not look straight at the fixture's LED source during operation. The intense light beam may damage your eyes. Sensitive persons may suffer an epileptic shock.
Provide advance notice that strobe lighting is in use.***

CAUTION! Risk group 2, RG-2
Avoid looking directly into the light source.



Do not view the light output with optical instruments or any device that may concentrate the beam.

WARNING! This unit does not contain an ON/OFF switch. Always disconnect the power input cable from mains to completely remove power from unit when not in use or before cleaning or servicing the unit.

When choosing the installation spot, please make sure that the fixture is not exposed to extreme heat or dust.

Do not block the front glass cover with any object when the fixture is under operation.

The fixture becomes very hot during operation. Allow the fixture to cool approximately 20 minutes prior to manipulate with it.

Only operate the fixture after having checked that the housing is firmly closed and all screws are tightly fastened.

Always use a safety wire for overhead installation.

Make sure that the area below the installation place is blocked when rigging, derigging or servicing the fixture.

The maximum ambient temperature must never be exceeded.

CAUTION!
The front glass cover has to be replaced when it is obviously damaged, e. g. due to cracks or deep scratches!

Operate the device only after having familiarized with its functions. Do not permit operation by persons not qualified for operating the device. Most damages are the result of unprofessional operation!

CAUTION!
To avoid damage of the internal parts of the fixture head, never let the sunlight (or other light source) lights directly to the front glass cover, even when the fixture is not in operation !

Please use only an original ROBE packaging (paper box, loader case or foam shell) for transporting the device, otherwise potential damage of the device during its transport will not subject to warranty.

Do not touch the device's housing bare hands during its operation (housing becomes hot)!

For replacement use fuse of the same type and rating only.

The fixture housing never must be covered with cloth or other materials during its operation. Do not block fans or fans ventilation slots with any object. Fans and ventilation slots must remain clean.

The fixture must not come into contact with sea water (salt water). Damages or corrosion issues resulting from salt water will void the manufactures warranty and will not be subject to any warranty claims or repairs.

The product (covers and cables) must not be exposed to a high frequency electromagnetic field higher than 3V/m.

Immunity of the equipment is designed according to the standard EN 55035 Electromagnetic compatibility of multimedia equipment - Immunity requirements.

Emission of the equipment complies with the standard EN55032 Electromagnetic compatibility of multimedia equipment – Emission Requirements according to class B.

Contains FCC ID: 2A6PL-DMXRDMRW001

Contains IC: 29573-DMXRDMRW001

This device complies with part 15 of the FCC Rules. Operation is subject to the following two conditions: (1) This device may not cause harmful interference, and (2) this device must accept any interference received, including interference that may cause undesired operation.

Changes or modifications not expressly approved by the party responsible for compliance could void the user's authority to operate the equipment.

The [Device] wireless operation is safe and complies to RF Exposure requirements

This equipment has been tested and found to comply with the limits for a Class B digital device, pursuant to part 15 of the FCC Rules. These limits are designed to provide reasonable protection against harmful interference in a residential installation. This equipment generates, uses and can radiate radio frequency energy and, if not installed and used in accordance with the instructions, may cause harmful interference to radio communications. However, there is no guarantee that interference will not occur in a particular installation. If this equipment does cause harmful interference to radio or television reception, which can be determined by turning the equipment off and on, the user is encouraged to try to correct the interference by one or more of the following measures:

- Reorient or relocate the receiving antenna.
- Increase the separation between the equipment and receiver.
- Connect the equipment into an outlet on a circuit different from that to which the receiver is connected.
- Consult the dealer or an experienced radio/TV technician for help.

2. Fixture exterior view

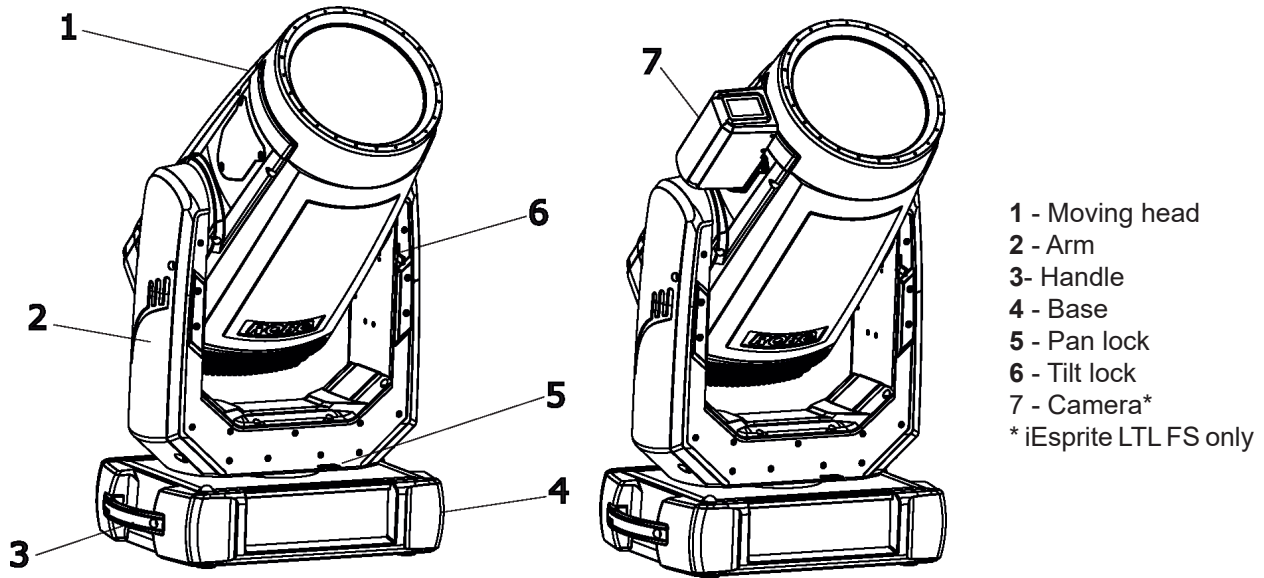

The head has to be locked for transportation - the tilt lock latch (6) and the pan lock latch (5) have to be in the locked positions. To unlock the head, move these latches to unlock position before operating the fixture.

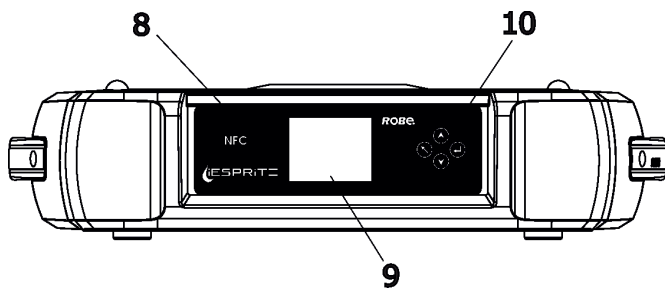

Front panel of the base

- 8 - NFC point
- 9 - Display
- 10 - Control buttons

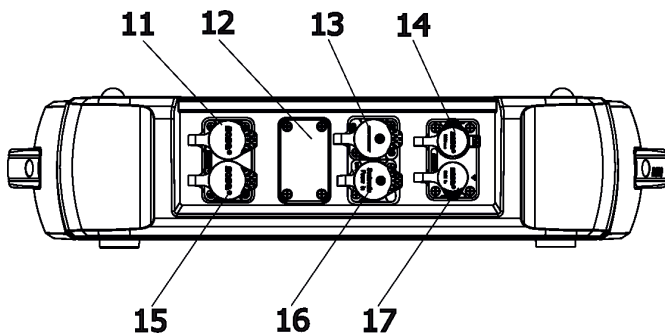

Rear panel of the base

- 11 - Ethernet Out (RJ45)
- 12 - Cover of battery and fuse holders
- 13 - Camera Out (RJ45) Power
- 14 - DMX Out (5-pin XLR)
- 15 - Ethernet In (RJ45)
- 16 - Power
- 17 - DMX In (5-pin XLR)

3. Installation



Fixtures must be installed by a qualified electrician in accordance with all national and local electrical and construction codes and regulations.

The Robin iEsprite's panel connectors are dust and water protected according to IP 65 by mating with related cable connectors. They cannot stay disconnected outdoor.

All unused panel connectors have to be sealed by the rubber caps.

Visually check panel connectors on accidental water leaks before connecting related cable connectors.

If some water will appear in panel connectors, do not connect cable connectors, especially power!

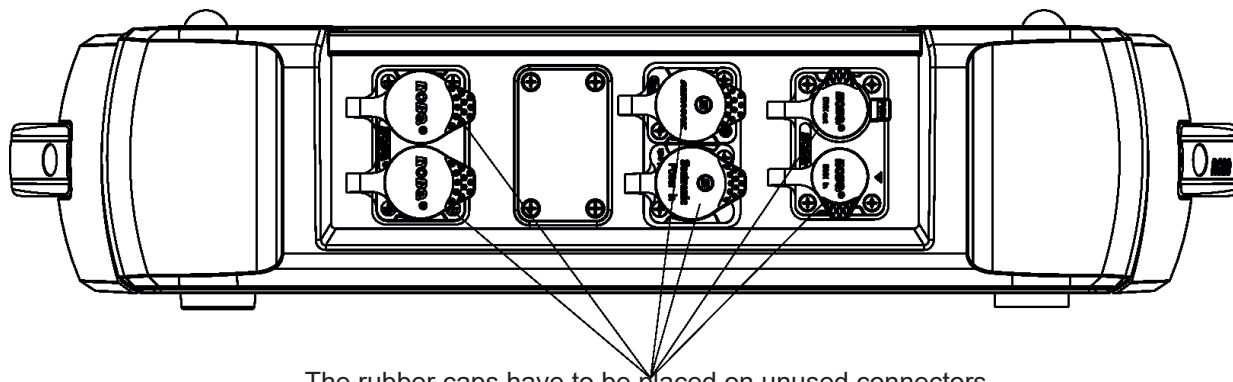

The rubber caps have to be placed on unused connectors.

The fixture must not come into contact with sea water (salt water).

3.1 Connection to the mains

To apply power, first check that the head pan and tilt locks are released.

**For protection from electric shock, the fixture must be earthed!
The fixture has to be connected to an electric outlet which is equipped with a residual-current device (residual-current circuit breaker)!**

Wiring and connection work must be carried out by a qualified electrician.

The Robin iEsprite LTL is equipped with auto-switching power supply that automatically adjusts to any 50-60Hz AC power source from 100-240 Volts.

Mains cable powerCON TRUE1 In/open ended is enclosed to the fixture. We recommend to install cord end-sleeves 1.5 x 8 (cross section in mm² x length in mm) on the cords of the mains cable. If you need to install a power plug on the mains cable to allow connection to power outlets, install a grounding-type (earthed) plug, following the plug manufacturer's instructions. If you have any doubts about proper installation, consult a qualified electrician. Connection to mains has to keep IP 65 protection rating.

Core (EU)	Core (US)	Connection	Plug Terminal Marking
Brown	Black	Live	L
Light blue	White	Neutral	N
Yellow/Green	Green	Earth	PE/GND

This device falls under class one and must be earthed (grounded).

Ensure all connections and the power plug on the cable are properly sealed.

3.2 Installing removable handles

Two removable handles installed on the arms of the fixture make it easier to handle the fixture.

Unplug the fixture from mains before removable handles installing!

To install removable handles.

1. Insert the removable handle (1) into slots (2) on both sides of the arm.
2. Removable handle (1) has to be inserted in the slot in this way that both rabbets (3) and (5) are under pins (4) and (6).
3. Move the removable handle (1) up until it snaps into lock mechanism and the removable handle is firmly locked in the arm.

Important: Do not pull the lock (7) towards the grip (8) of the removable handle (1) during manipulation with the fixture via the removable handles!

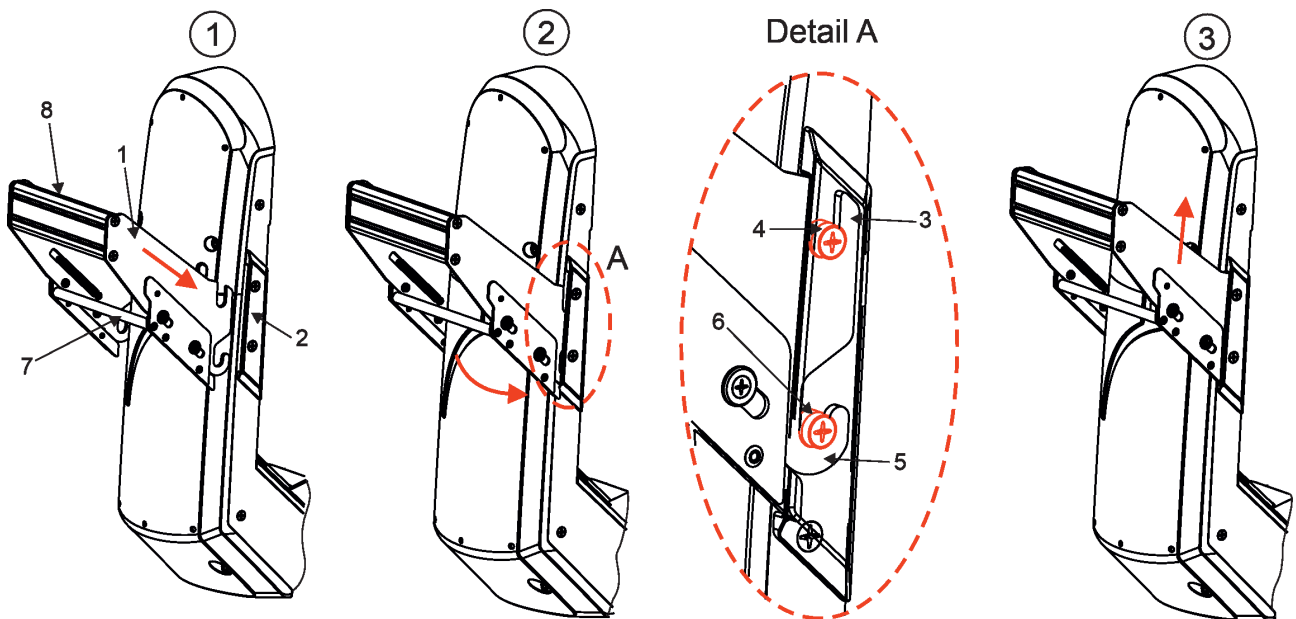

To unistall removable handles.

1. Pull the lock (7) towards the grip of the removable handle (8) as shown in the picture below and keep it in this position.
2. Move the removable handle down.
3. Slide the removable handle (1) out from the slots (2) on the fixture arms.

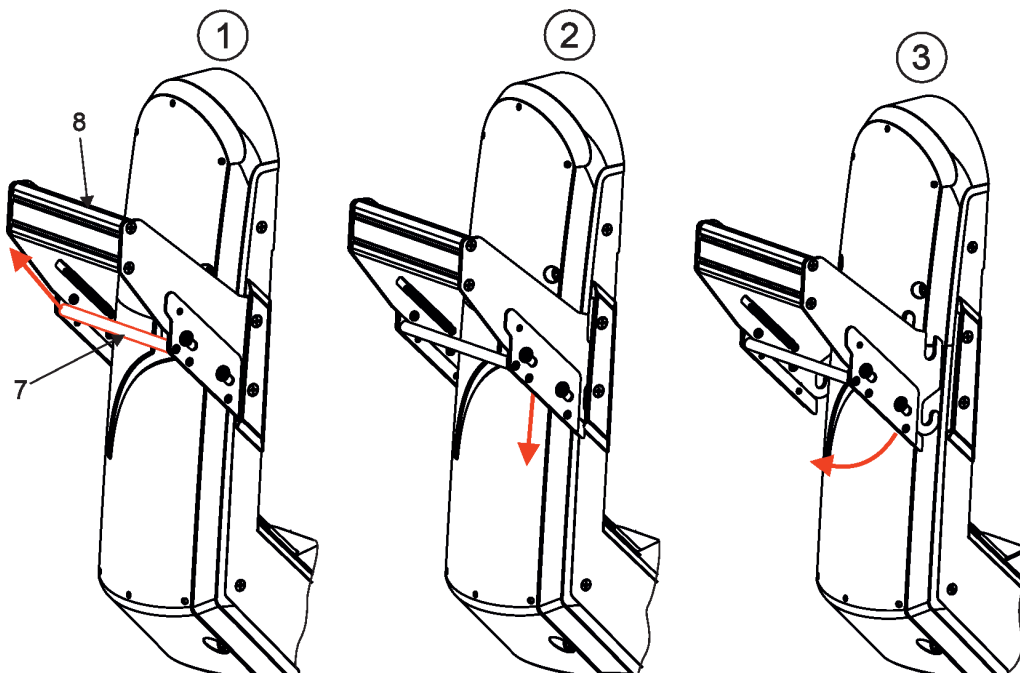

3.3 Replacing the frost

***Unplug the fixture from mains before replacing frost!
Do not replace frost in a damp environment (e.g. rain, snowfall)!
Do not remove fixture covers in smoky or particularly dirty
environment (e.g. with fog machines).***

To replace the frost.

1. Disconnect the fixture from mains and allow it to cool for 30 minutes.
2. Move the fixture head to the position as shown on the picture below (the pan and tilt locks have to be on the same side as the front panel) to determine which top cover of the head has to be removed. Remove the top cover of the head by unscrewing 6 hex socket head screws M5x16 on the cover to get access to the frost. .

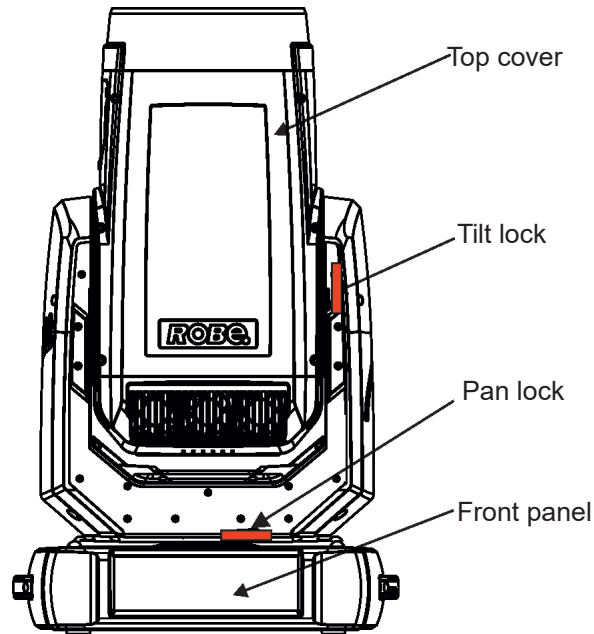

IMPORTANT: The fixture head should be uncovered as short time as possible (about 1-2 hours depending on air humidity) otherwise silica gel in the small boxes in the fixture head may become damp. If you have removed head cover and you need to interrupt your work for long time (hours, days), we recommend to place the head cover on the head and fasten it provisionally by means of two screws, next possibility is unscrewing small boxes with silica gel from the head and put it to a sealed container with limited access of air (e.g. sealed plastic bag).

3. The holder (2) of the frost foil is fastened to the frost holder (3) by means of the four magnets (4). Grip the holder (2) and carefully tilt it out to break a force of magnets (4) on the frost holder (3).

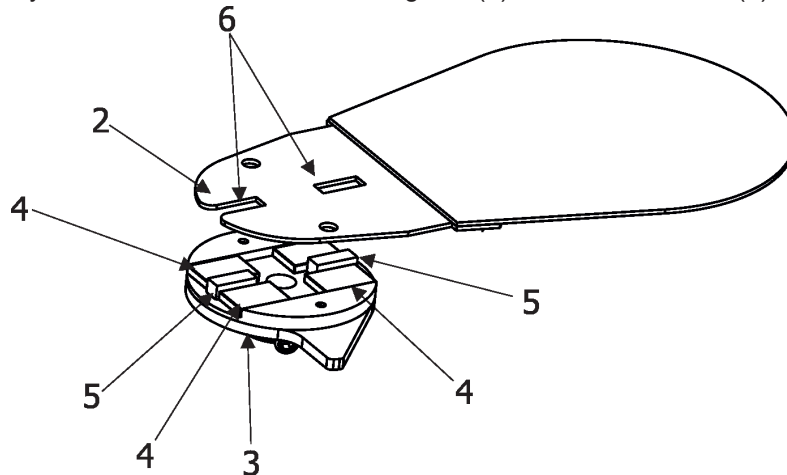

4. Place a new frost module into the frost holder (3). Check, that both slots (6) snapped correctly into two protrusions (5) in the holder (3).

5. Check silica gel desiccants in the fixture head before placing head cover back on the fixture.
6. Place the head cover back on the fixture and screw it by means of the six hex socket head screws M5x16 before applying power. Keep required tightening torque as stated in the chapter Maintenance. Do not forget to connect grounding wire between chassis and head cover.
7. Run the procedure **Pressure Test (Service -->Pressure Test)**.

3.4 Replacing rotating gobos

***Unplug the fixture from mains before replacing the gobos!
Do not replace gobos in a damp environment (e.g. rain, snowfall)!
Do not remove fixture covers in smoky or particularly dirty environment (e.g. with fog machines)***

1. Close a light output of the fixture and allow the fixture to cool about 30 minutes.
2. Move the fixture head to the position as shown on the picture below (the pan and tilt locks have to be on the same side as the front panel) to determine which top cover of the head has to be removed. Remove the top cover of the head by unscrewing 6 hex socket head screws M5x16 on the cover to get access to the rot. gobos.

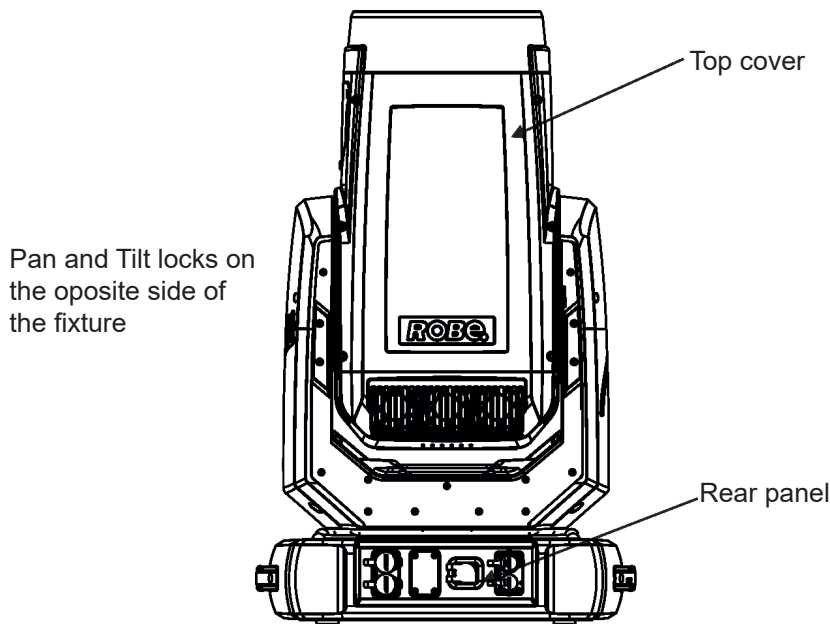

IMPORTANT: The fixture head should be uncovered as short time as possible (about 1-2 hours depending on air humidity) otherwise silica gel in the small boxes in the fixture head may become damp. If you have removed head cover and you need to interrupt your work for long time (hours, days), we recommend to place the head cover on the head and fasten it provisionally by means of two screws, next possibility is unscrewing small boxes with silica gel from the head and put it to a sealed container with limited access of air (e.g. sealed plastic bag).

3. Connect the fixture to mains. Go to the tab "Service", select the menu "Adjust DMX values " and move the fixture head to the position which is suitable for changing rot. gobos.

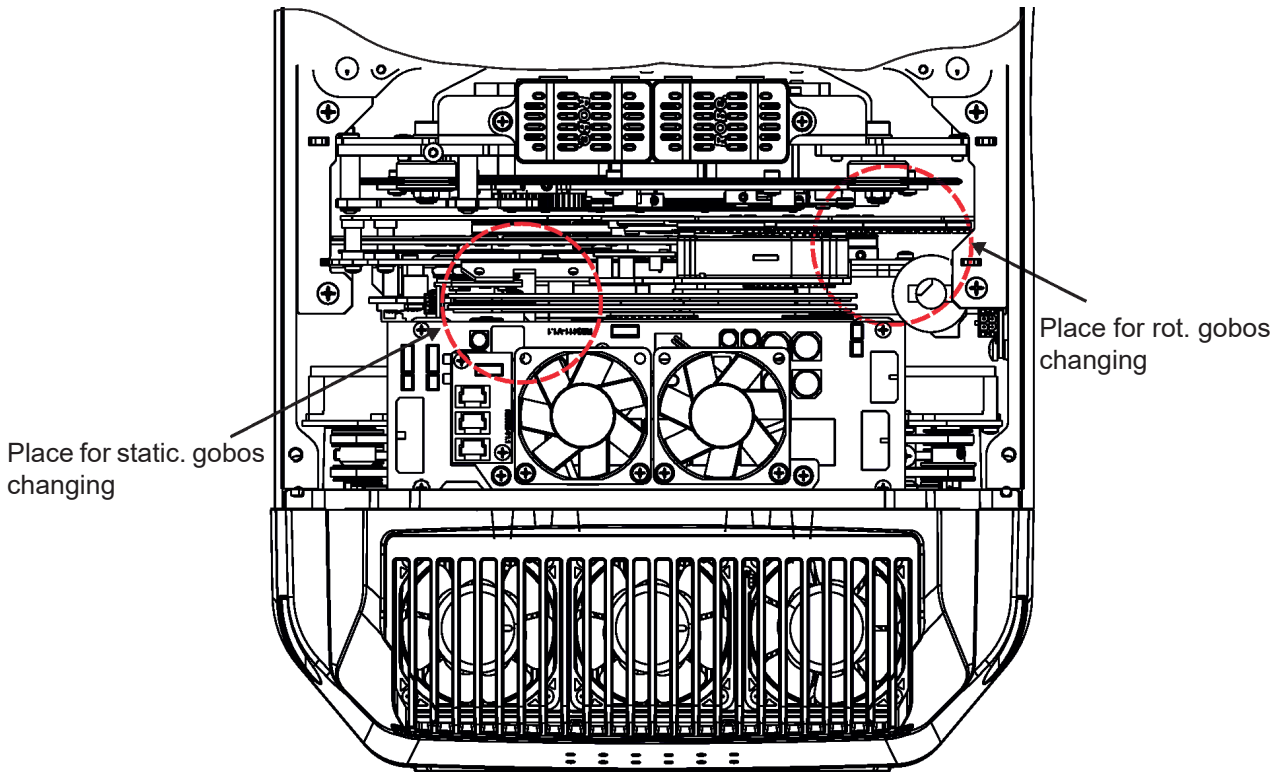

4. Escape from the menu "Adjust DMX values " and go to the menu " Rotating Gobos Change" in the same tab, select Gobo Carousel 1 and enter to its menu.
5. Select a gobo (G1-Mg, G2, G3, G4, G5, G6, G7) which you wish to replace. The selected gobo will move to the accessible position for its changing.
Note: "G1-Mg" means the gobo holder with a magnet.
6. Check that the position point (4) on the gobo holder aims exactly to the toothlike projection (6) on the edge of the rotating gobo wheel. If not, go to the option "Gobo Offset" and adjust the position point (4) exactly opposite of the toothlike projection(6). Adjusted value in the "Gobo Offset" is valid for all gobos on the gobo carousel.

Note: The magnet (7) on the gobo holder substitutes the position point (4).

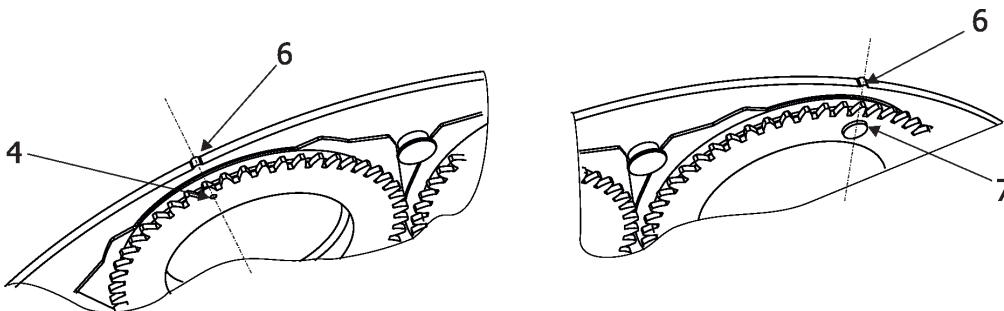

7. Gently pull up the gobo holder (3) from the rotation gobo carousel.
8. Remove the spring lock (1) with an appropriate tool (e.g. small-bladed screwdriver).
Do not touch the surface of the glass gobo with bare fingers.
9. Remove the original gobo (2) and insert the new one (grey side towards the light source, black side towards the front lens).
The Robe gobo has a small position point (5) at its edge which has to aim at the position point (4) on the gobo holder (3). Insert the spring lock (1) to secure correct gobo position in the gobo holder (3).

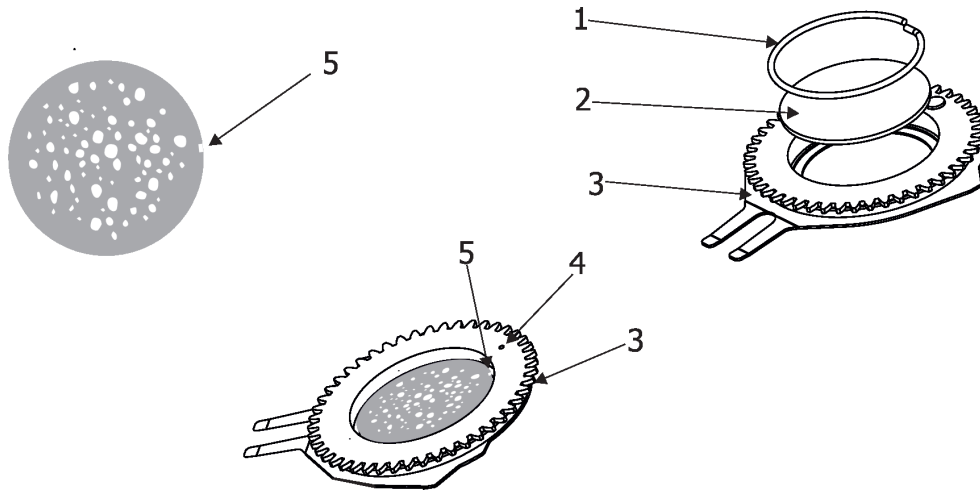

10. Insert the gobo holder back into gobo carousel in this way, that its position point (4) (or magnet (7)) has to exactly aim at a small toothlike projection (6) on the edge of the rotating gobo wheel. Do not move with neighbouring gobo holders.

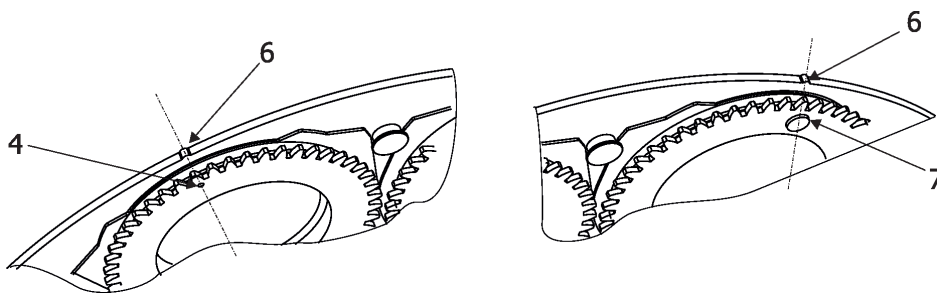

11. Escape the gobo item and enter another gobo item which you want to replace. You do not need to set the gobo offset again. Repeat steps 5-10 for all gobos which you need to replace on the gobo carousel.
Note. The hot-spot lens with holder (optional accessories) can be installed instead of the rot. gobo 7.

12. **After replacing desired gobos, connect the fixture to mains and light on changed gobo holders (or gobos) with max. intensity (shutter/dimmer=255 DMX) approximately 10 minutes per each changed gobo position to evaporate potential grease from gobo holders and gobos.**

During this procedure, the fixture head has to be in a horizontal position without top cover (side of fixture head without cover has to be up) and the gobo has to rotate.

Note: this step you can leave out if you use original gobo holders from the fixture and you sure that new glass gobos are clean.

13. After "gobo burning", check silica gel desiccants in the fixture head before placing head cover back on the fixture.

14. Place the head cover back on the fixture and screw it by means of the six hex socket head screws M5x16. Do not forget to connect grounding wire between chassis and head cover. Keep required tightening torque as stated in the chapter Maintenance.

15. **Run the procedure Pressure Test (tab Service -->Pressure Test).**

Note: The optical system of the fixture turns the gobo picture upside down and mirrors it:

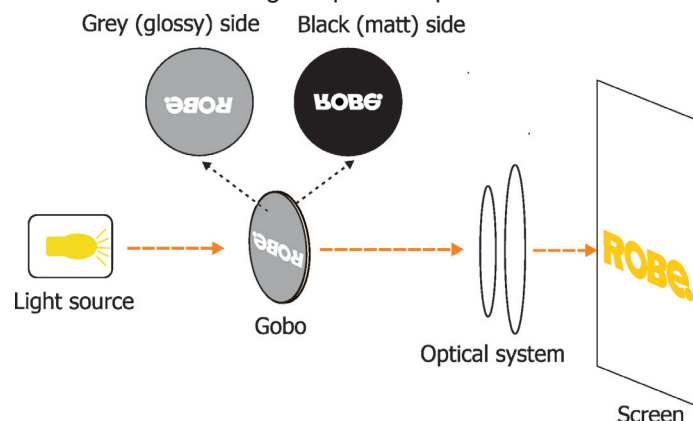

3.5 Replacing static gobos

**Unplug the fixture from mains before replacing the gobos!
Do not replace gobos in a damp environment (e.g. rain, snowfall)!
Do not remove fixture covers in smoky or particularly dirty
environment (e.g. with fog machines)**

1. Close a light output of the fixture and allow the fixture to cool about 30 minutes.
2. Move the fixture head to the position as shown on the picture below (the pan and tilt locks have to be on the same side as the front panel) to determine which top cover of the head has to be removed. Remove the top cover of the head by unscrewing 6 hex socket head screws M5x16 on the cover to get access to the static gobo.

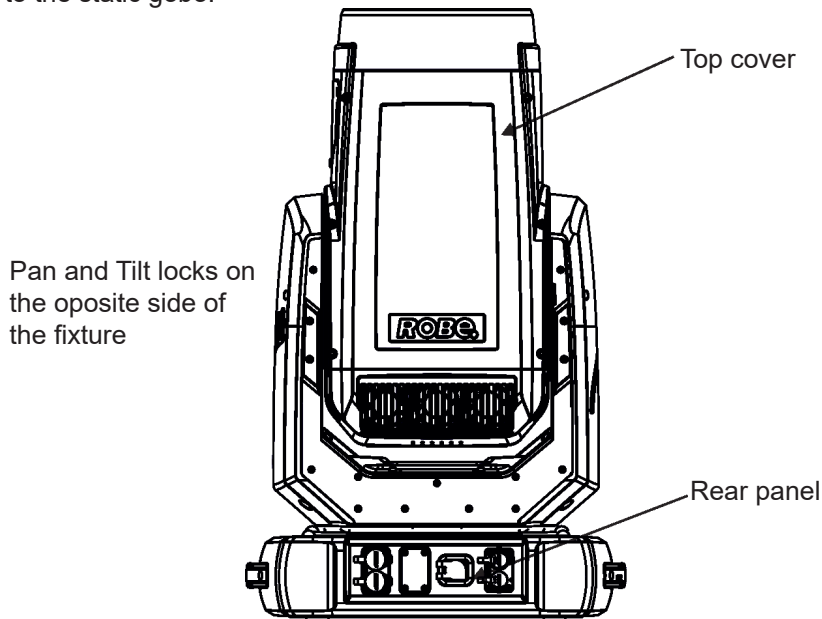

IMPORTANT: The fixture head should be uncovered as short time as possible (about 1-2 hours depending on air humidity) otherwise silica gel in the small boxes in the fixture head may become damp. If you have removed head cover and you need to interrupt your work for long time (hours, days), we recommend to place the head cover on the head and fasten it provisionally by means of two screws, next possibility is unscrewing small boxes with silica gel from the head and put it to a sealed container with limited access of air (e.g. sealed plastic bag).

3. Gently pull up the gobo holder (1) from the static gobo wheel.
4. Remove the spring gobo lock (3) with an appropriate tool (e.g. small-bladed screwdriver) and remove it. Do not touch the surface of the pattern of the glass gobo.
5. Remove the original gobo (2) and insert the new one (glazy side towards the light source). Insert the spring gobo lock (3) to secure it in the gobo holder (1).
6. Insert the gobo holder back to the static gobo wheel until it reaches the stop (4) in the static gobo wheel.
7. Place the head cover back on the fixture and screw it by means of the six hex socket head screws M5x16. Do not forget to connect grounding wire between chassis and head cover. Keep required tightening torque as stated in the chapter Maintenance.
8. Run the procedure **Pressure Test** (tab **Service** -->**Pressure Test**).

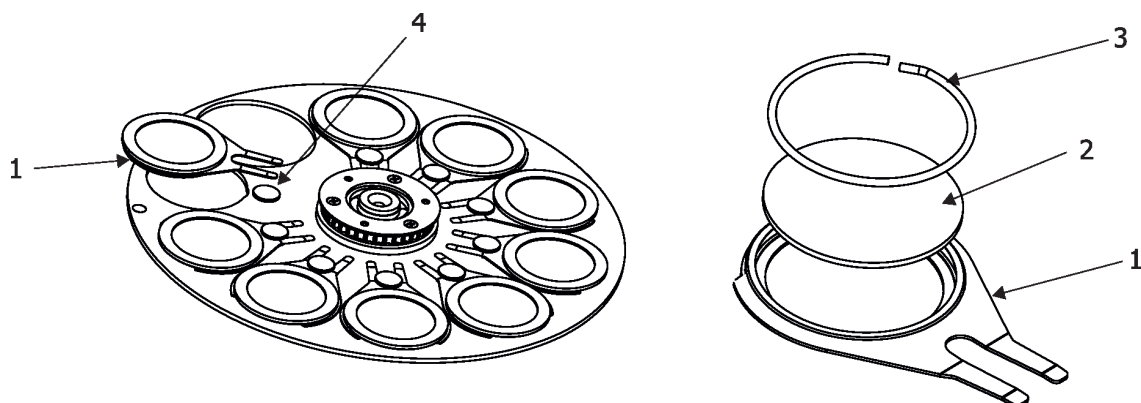

3.6 Camera installation

Unplug the fixture from mains before installing the camera!

The iEsprite LTL WB is ready for installation of the camera. The FS LTL, LTX CamFit kit (P/N 10980885) includes:

- 1 x camera
- 1 x RJ45 connection cable
- 1 x heat insulation pad with silica gel box (P/N 99030474)
- 3 x screws M4x12

To install camera.

1. Disconnect the fixture from mains.
2. Remove the balancing weight cover (1) of camera connection compartment (2) by unscrewing three screws(3).
3. Insert the heat insulation pad with silica gel box (4) into camera connection compartment, connect the camera with RJ45 socket in the camera connection compartment by means of RJ45 cable.
4. Screw the camera (5) to the camera connection compartment using three screws (6) enclosed in the camera kit. Tighten screws in order 1-->3, use tightening torque 0.5Nm (pre-tightening) and 2.5Nm for final tightening.
5. Keep the balancing weight cover (1) with three screws for future use in case of removing the camera from the fixture.
6. Run the procedure **Pressure Test (tab Service -->Pressure Test)**.

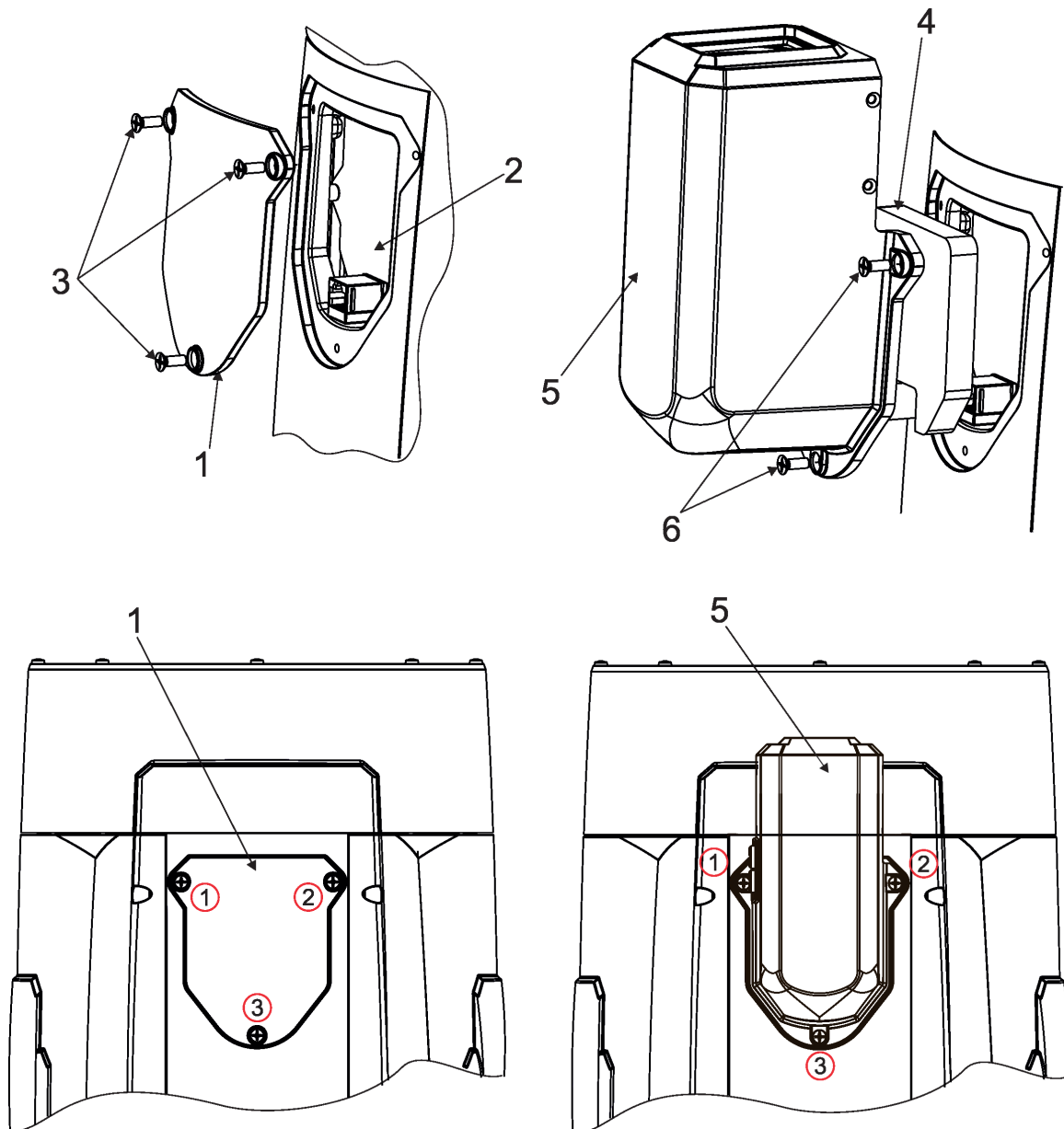

3.7 Rigging the fixture

A structure intended for installation of the fixture(s) must safely hold weight of the fixture(s) placed on it. The structure has to be certificated to the purpose.

The fixture (fixtures) must be installed in accordance with national and local electrical and construction codes and regulations.

For overhead installation, the fixture must be always secured with a safety wire that can bear at least 10 times the weight of the fixture

When rigging, derigging or servicing the fixture staying in the area below the installation place, on bridges, under high working places and other endangered areas is forbidden.

The operator has to make sure that safety relating and machine technical installations are approved by an expert before taking into operation for the first time and after changes before taking into operation another time.

The operator has to make sure that safety relating and machine technical installations are approved by a skilled person once a year.

Allow the fixture to cool for ten minutes before handling.

The fixture should be installed outside areas where persons may walk by or be seated.

IMPORTANT! OVERHEAD RIGGING REQUIRES EXTENSIVE EXPERIENCE, including calculating working load limits, installation material being used, and periodic safety inspection of all installation material and the projector. If you lack these qualifications, do not attempt the installation yourself, but use a help of professional companies.

CAUTION: Fixtures may cause severe injuries when crashing down! If you have doubts concerning the safety of a possible installation, do not install the fixture!

The fixture has to be installed out of the reach of public.

The fixture must never be fixed swinging freely in the room.

***Danger of fire !
When installing the device, make sure there is no highly inflammable material (decoration articles, etc.) in a distance of min. 1 m.***

***CAUTION!
Use 2 appropriate clamps to rig the fixture on the truss.
Follow the instructions mentioned at the bottom of the base.
Make sure that the device is fixed properly! Ensure that the structure (truss) to which you are attaching the fixtures is secure.***

The fixture can be placed directly on the stage floor or rigged on a truss without altering its operation characteristics .

For securing the fixture to the truss, install a safety wire which can hold at least 10 times the weight of the fixture. Use only the safety wire with a snap hook with screw lock gate.

Omega holders points

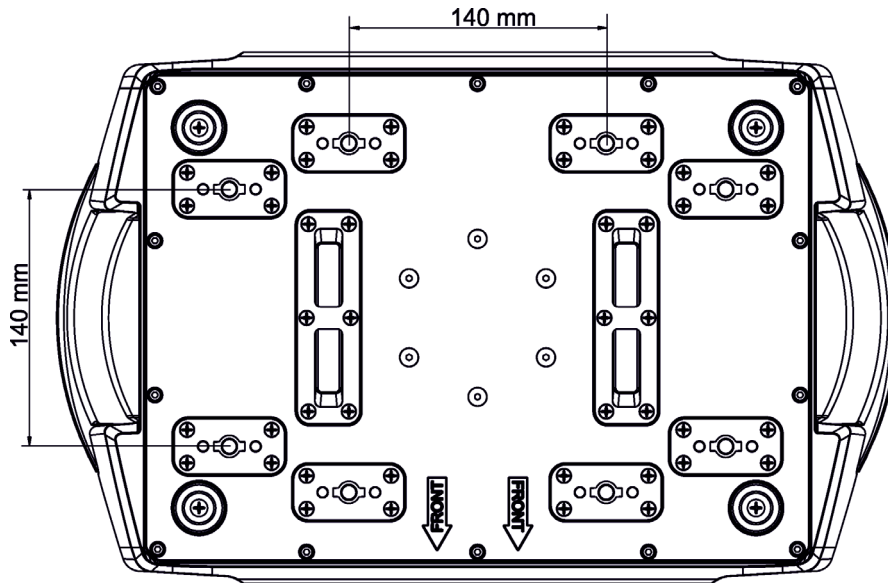

Truss installation

1. Bolt each clamp (1) to the Omega adaptor (2) with M12 bolt and lock nut through the hole in the adaptor.
2. Fasten the Omega adaptors to the bottom of the base by inserting both quick-lock fasteners (3) into the holes of the base and tighten them fully clockwise.
3. Clamp the fixture on a truss (6) and tighten the rigging clamps (1).
4. Pull one safety wire (4) around the truss (6) and through the handle (7) and lock the snap hook of the safety wire in the attachment point (5). We recommend to use another safety wire (4) and pull it around the truss (6) and through the second handle (7) and lock the snap hook of the safety wire in the attachment point (5) as shown on the picture below. Use safety wires of a suitable length that maximum fall of the fixture will be 20 cm.

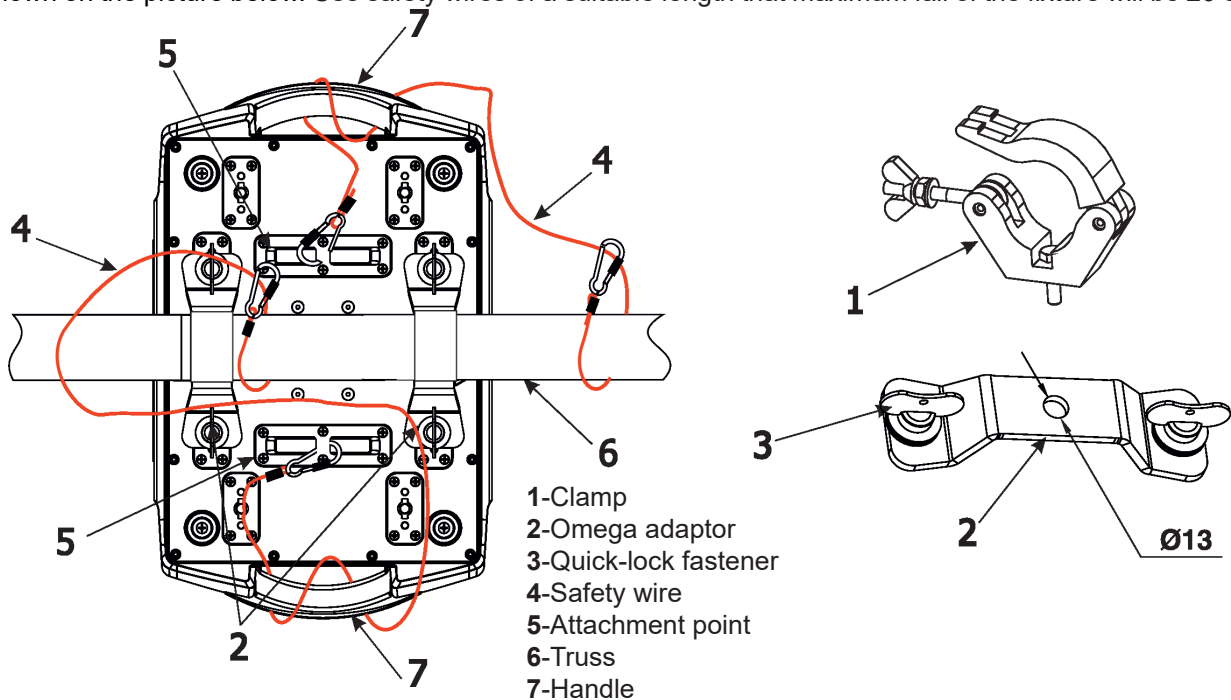

Note:

Surface corrosion of the Omega adaptors may occur, especially if this fixture has been used outdoors. Surface corrosion will not affect the safety of the Omega adaptors. Omega adaptors corrosion is not covered by the warranty.

***When installing fixtures side-by-side,
avoid illuminating one fixture with another!***

DANGER TO LIFE!
Before taking into operation for the first time, the installation has to be approved by an expert!

Allowed installation positions of the iEsprite LTL:

Side installation

Both position (1) and (2) are allowed but preferred position is (1).
If it is possible, use the position (1).

The item Pan/Tilt Speed must be set to "Reduced".

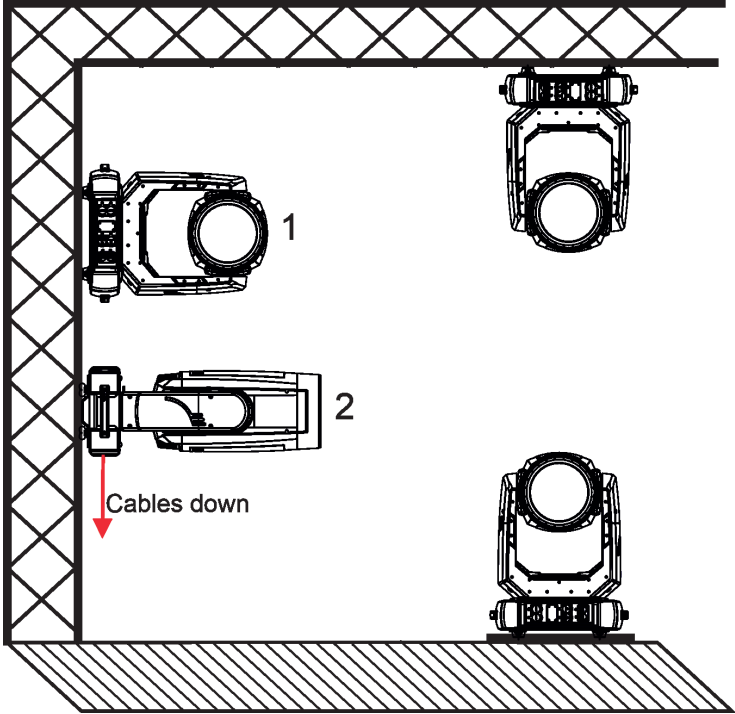

Note for open-air installation: if the fixture has to stand on the ground, min. distance of 4" (10cm) between the fixture base and the ground has to be kept.

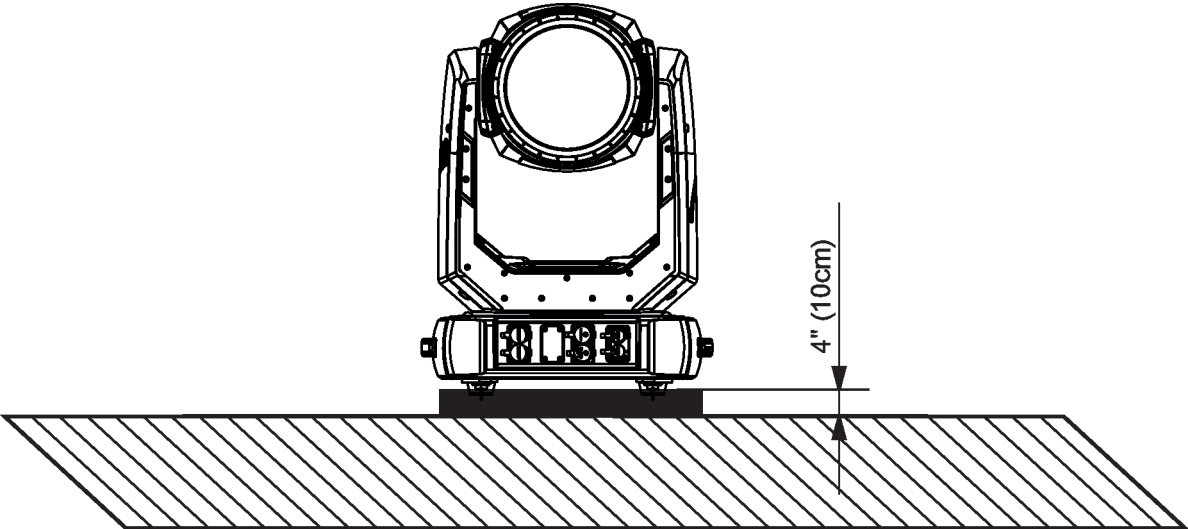

3.8 DMX-512 connection

The fixture is equipped with 5-pin XLR sockets for DMX input and output. Use a shielded twisted-pair cable designed for RS-485 and 5-pin XLR-plugs and connectors in order to connect the controller with the fixture or one fixture with another.

DMX output

XLR socket (female)



- 1 - Shield
- 2 - Signal (-)
- 3 - Signal (+)
- 4 - Not connected
- 5 - Not connected

DMX input

XLR socket (male)

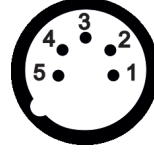

- 1 - Shield
- 2 - Signal (-)
- 3 - Signal (+)
- 4 - Not connected
- 5 - Not connected

If you are using the standard DMX controllers, you can connect the DMX output of the controller directly with the DMX input of the first fixture in the DMX chain. If you wish to connect DMX controllers with other XLR outputs, you need to use adaptor cables.

Building a serial DMX chain:

Connect the DMX output of the first fixture in the DMX chain with the DMX input of the next fixture. Always connect one output with the input of the next fixture until all fixtures are connected. Up to 32 fixtures can be connected.

Caution: At the last fixture, the DMX cable has to be terminated with a terminator. Solder a 120 Ω resistor between Signal (-) and Signal (+) into a 5-pin XLR plug and plug it in the DMX output of the last fixture.

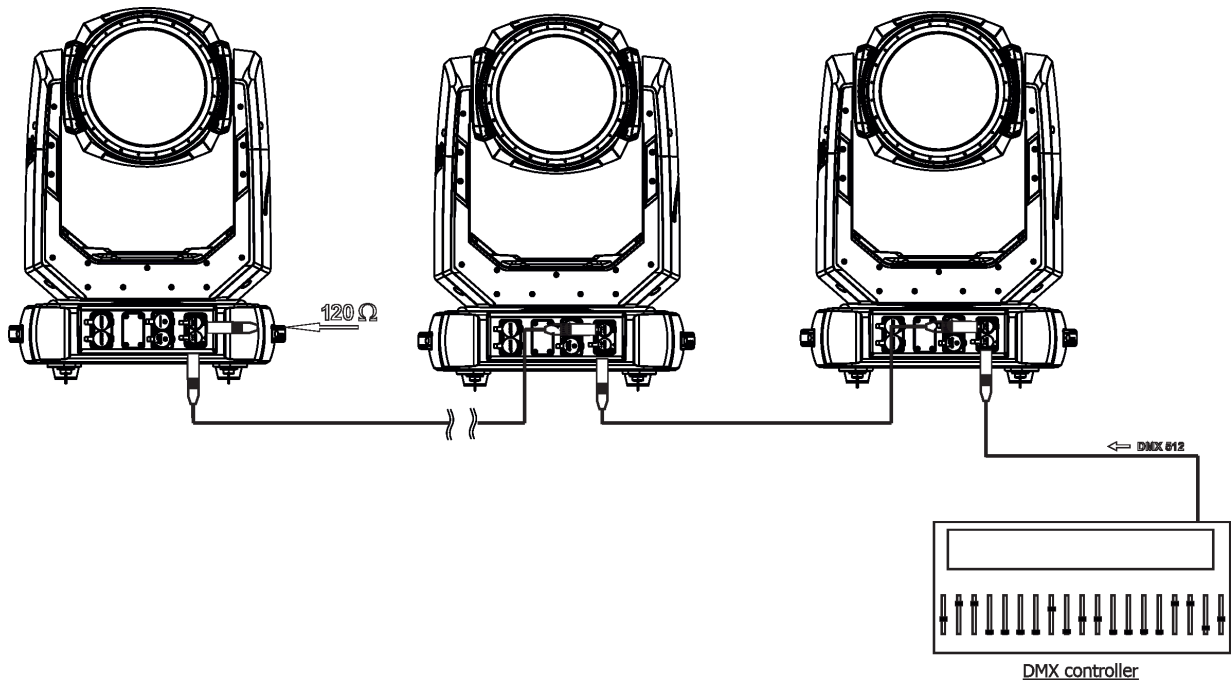

3.9 Ethernet connection

The fixtures on a data link are connected to the Ethernet with appropriate communication protocol (e.g. Art-Net). The control software running on your PC (or light console) has to support Art-Net protocol. Art-Net communication protocol is a 10 Base T Ethernet protocol based on the TCP/IP. Its purpose is to allow transfer of large amounts of DMX 512 data over a wide area using standard network technology.

IP address is the Internet protocol address. The IP uniquely identifies any node (fixture) on a network. **The Universe** is a single DMX 512 frame of 512 channels.

The Robin iEsprite is equipped with 8-pin RJ-45 sockets for Ethernet connection. Use a network cable category 5 (with four "twisted" wire pairs) and standard RJ-45 plugs in order to connect the fixture to the network.

RJ-45 socket (front view):

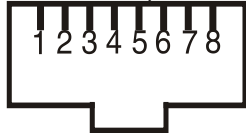

- 1- TD+
- 2- TD-
- 3- RX+
- 4- Not connected
- 5- Not connected
- 6- RX-
- 7- Not connected
- 8- Not connected

RJ-45 plug (front view):

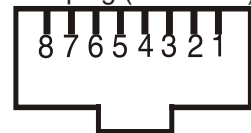

Patch cables that connect fixtures to the hubs or LAN sockets are wired 1:1, that is, pins with the same numbers are connected together:



If only the fixture and the computer are to be interconnected, no hubs or other active components are needed. A cross-cable has to be used:



If the fixture is connected with active Ethernet socket (e.g. switch) the network icon  will appear at the bottom right corner of the screen:

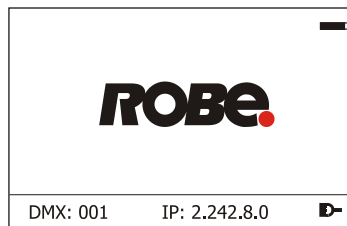

Ethernet operation

Connect the Ethernet inputs of all fixtures with the Ethernet network. Option "Artnet" (gMal or gMA2 or sACN) has to be selected from "Ethernet Mode" menu at each fixture. Set IP address (002.xxx.xxx.xxx / 010.xxx.xxx.xxx) and the Universe at each fixture.

(DMX address=197)
IP address=002.168.002.004
Universe=1

(DMX address=54)
IP address=002.168.002.003
Universe=1

(DMX address=1)
IP address=002.168.002.002
Universe=1

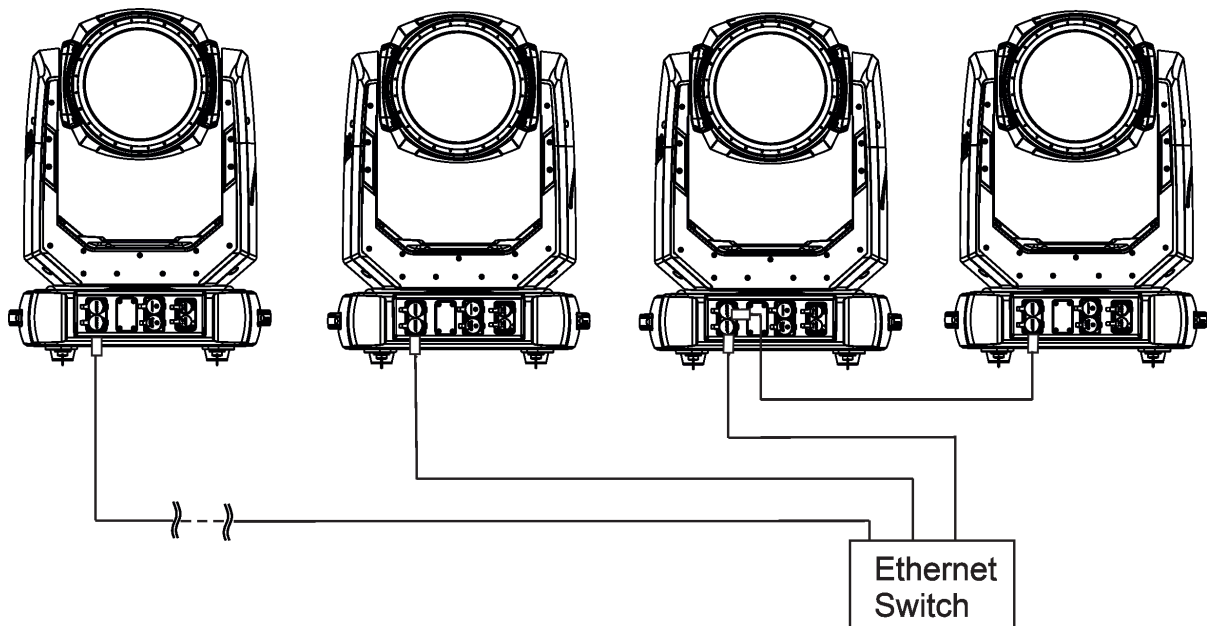

An advised PC setting: IP address: 002.xxx.xxx.xxx (Different from fixture IP addresses)
NET mask: 255.0.0.0

The fixture is equipped with Ethernet Pass through switch which sustains Ethernet integrity, when the fixture has no power, it automatically maintains network connectivity.

If you use the Ethernet IN-OUT way for the Ethernet connection, max. 8 fixtures can be connected in the IN-OUT line.

Ethernet / DMX operation

Option "Artnet" (gMal or gMA2 or sACN) has to be selected from "Ethernet Mode" menu at first fixture. Option "Ethernet To DMX" has to be selected from the "Ethernet Mode" menu at the first fixture (connected to the Ethernet) in the fixture chain, next fixtures have standard DMX setting.

Connect the Ethernet input of the first fixture in the data chain with the network. Connect the DMX output of this fixture with the input of the next fixture until all fixtures are connected to the DMX chain.

Caution: At the last fixture, the DMX chain has to be terminated with a terminator. Solder a 120 Ω resistor between Signal (-) and Signal (+) into a XLR-plug and connect it in the DMX-output of the last fixture.

Example:

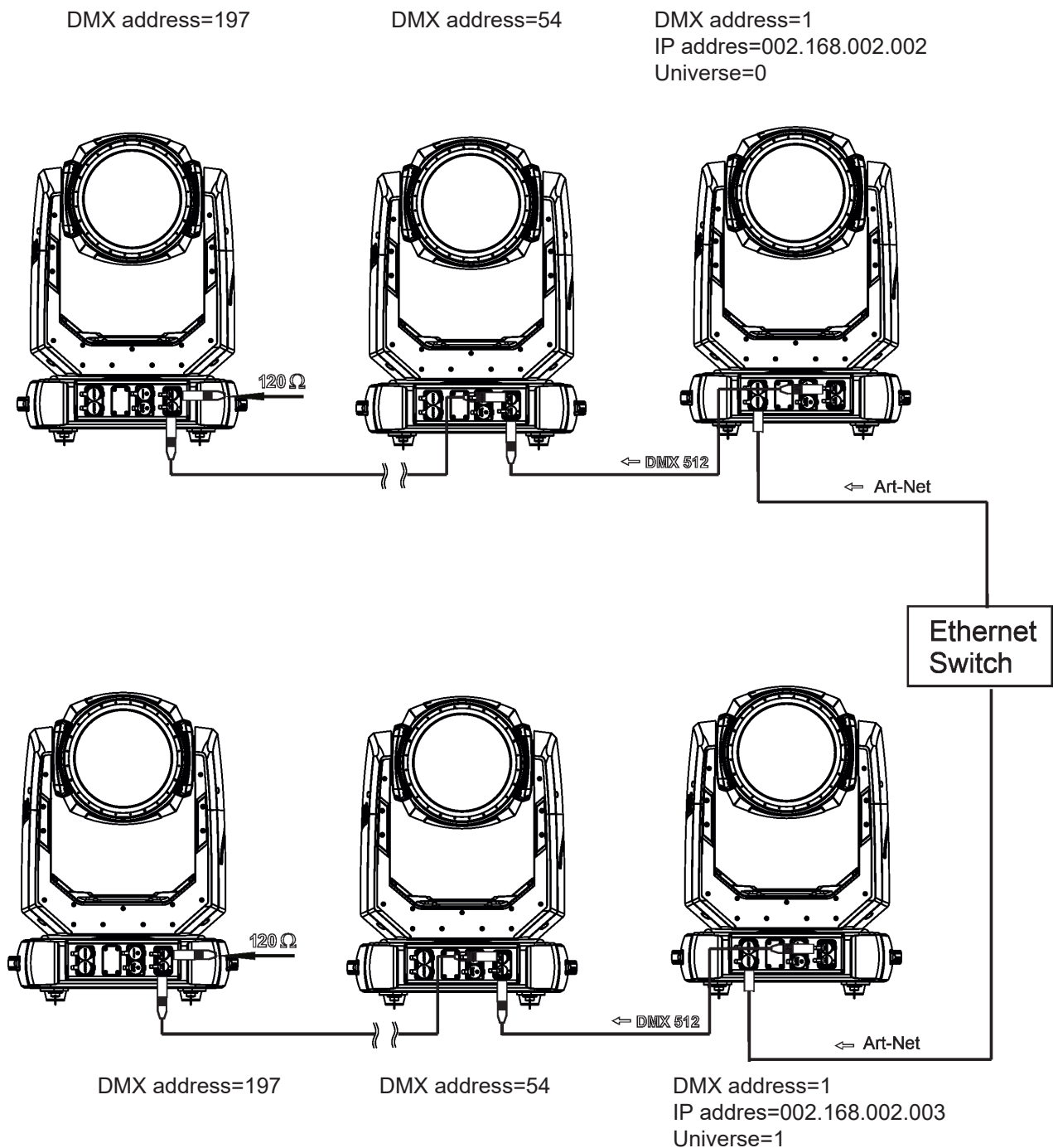

3.10 Wireless DMX operation

The ROBE wireless DMX/RDM module has full support for wireless communication protocols at entertainment market. Module is based on well known LumenRadio RF technology, with implemented wire interface for connection with Robe products. RF output for MCX interface antenna as standard output.

The item " Wireless " from the menu "DMX Input" allows you to activate receiving of wireless DMX (Personality--> DMX Input -->Wireless.). First two options from the "DMX Input" menu are stated in DMX chart as well (channel Power/Special functions , range of 10-19 DMX). If DMX input option is changed by DMX command, the change is permanently written into fixture's memory.

DMX range of 10-19 switching fixture to the wired/wireless operation is active only during first 10 seconds after switching the fixture on.

After switching the fixture on, the fixture checks both modes of receiving DMX in the following order:

1. For the first five seconds, the fixture receives DMX signal from the wired input. If the Power/Special functions channel is set at some DMX input option, the fixture will receive DMX value according to this option. If DMX input option is set to the wired input , this option is saved and checking procedure is finished. If DMX input option is not set, the fixture continues next 5 seconds in scanning wireless DMX signal-see point 2.

2. For the next 5 seconds the fixture receives wireless DMX signal and again detects if the Power/Special functions channel is set at some DMX input option, if not, the fixture will take option which is set in the fixture menu "DMX Input".

To link the fixture with DMX transmitter.

The fixture can be only linked with the transmitter by running the link procedure at DMX transmitter . After linking , the level of DMX signal (0-100 %) is displayed in the menu item "Wireless State" (Information -->Wireless State).

To unlink the fixture from DMX transmitter.

The fixture can be unlinked from transmitter via the menu item " Unlink Wireless Adaptor" (Information--> Wireless State --> Unlink Wireless Adaptor).

Note: If the option "Wireless In/XLR Out" is selected (Personality--> DMX Input -->Wireless In/XLR Out), the fixture receives wireless DMX and sends the signal to its wired DMX output. The fixture behaves as " Wireless/Wired" adaptor.

Example of connection:

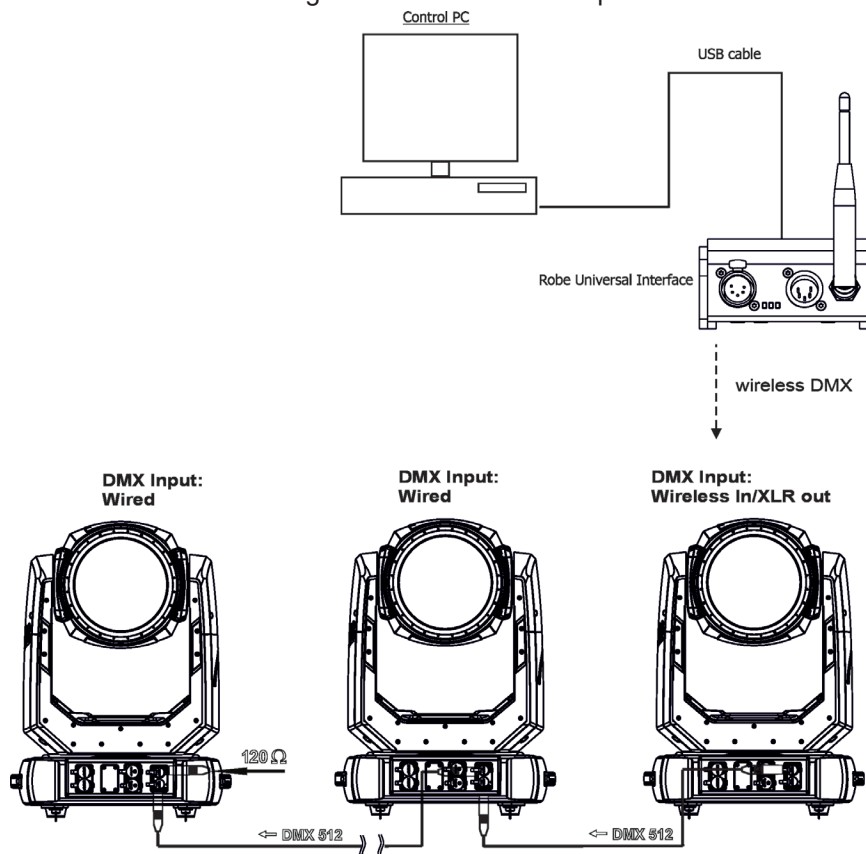

4. Checking the IP65 integrity of the fixture.

The Robin iEsprite is IP65 rated lighting fixture which has been designed to be protected against the ingress of dust and pressure water jets from any direction.

1. Smart pressure test - for this test serves the function "Pressure Test" in the tab Service. Unique testing procedure allows you easy testing of the IP65 integrity of the fixture. You do not need any external device connected to the fixture for running the test.

The fixture has to be connected to mains (must not be in Standby mode) and a head temperature (at pressure sensor) cannot be higher than 55°C. The pressure test takes about 8 minutes and can be run at earliest 10 minutes after closing light output of the fixture. The pressure test can be repeated at earliest 2 minutes after last pressure test.

The function "Pressure Test" should be run after the following actions:

- **unscrewing/screwing back any watertight cover** (e.g. due to gobos or frosts change)
- **replacing pan or tilt motor**
- **replacing LED light source**
- **replacing desiccants in the fixture arm (two tubes with silica gel).**

The pressure test can be also run by DMX command (channel Power/Special function) or from web interface REAP (Robe Ethernet Access Portal). During the pressure test fixture does not respond to DMX commands (except DMX value 9 on the channel Power/Special functions).

Examples of screens (front panel display) of the smart pressure test:

Fixture waits for 10 minutes period elapsing (inside of the fixture is too hot)

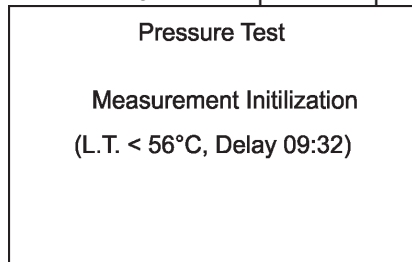

Fixture waits for 2 minutes period elapsing (repeated pressure test was run too early)

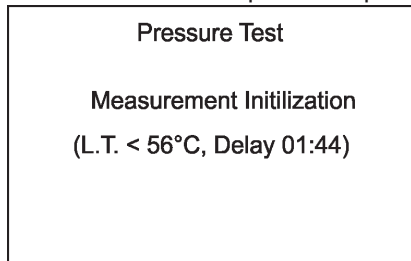

Setting fans

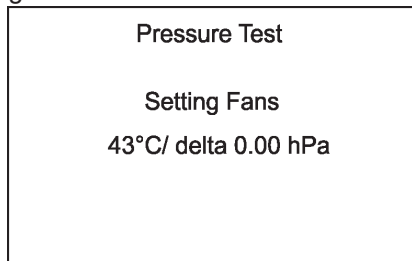

Test in progress

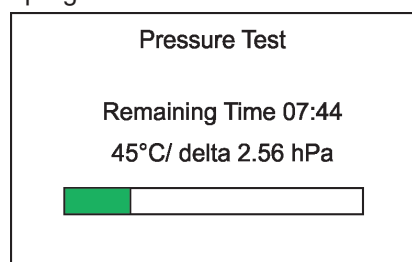

Legend:

07:44Remaining Time (minutes) to finish of pressure test.
45°C.....Temperature at pressure sensor.
delta 2.56 hPa...Pressure difference.
The pressure difference has to be >7 hPa for successful test.

Test passed

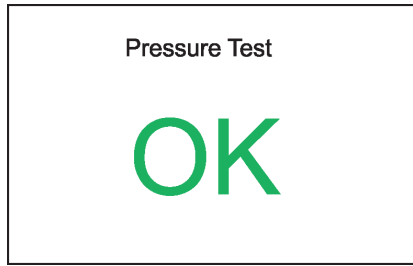

Test failed

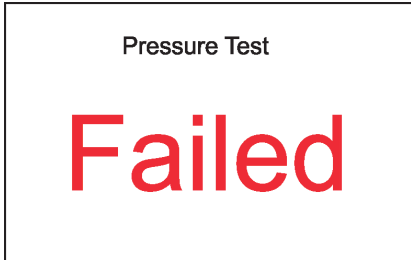

If the first pressure test failed and the second is OK, the fixture complies with IP65 integrity. If the pressure test twice fails despite checking of correct tightening of the cover screws and gaskets under covers, the fixture has to be tested by means of "Enhanced pressure test". For this type of pressure test is needed the Pressure IP Testing Set ROBE (P/N 10980659). Please ask your ROBE distributor for help.

The message "Valve Seal Error" means that valve or coil in the valve is defective or there is a connection problem.

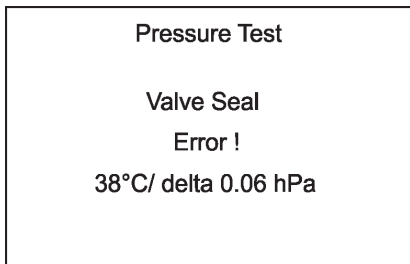

Check the connection between the valve and head, especially cable connector. Other reason can be faulty coil in the valve or faulty valve.

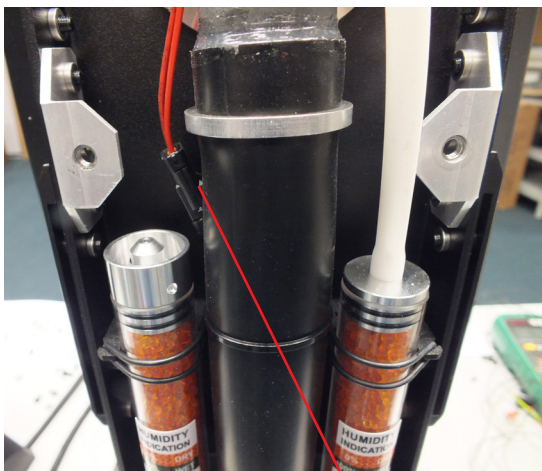

Cable connector
(arm without tilt lock)

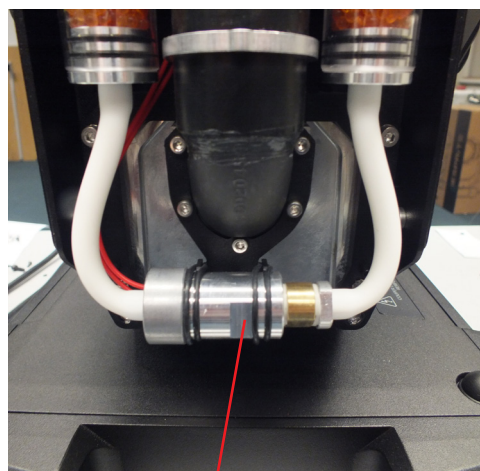

Valve
(arm without tilt lock)

The message "Not Available At The Moment" means that the fixture is not connected to mains.

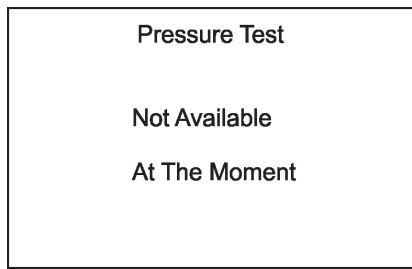

2. Enhanced pressure test - a special equipment Pressure IP Testing Set ROBE (P/N 10980659) is intended for this kind of pressure test. Only trained technician should handle the equipment.

Pressure IP Testing Set ROBE
in case:

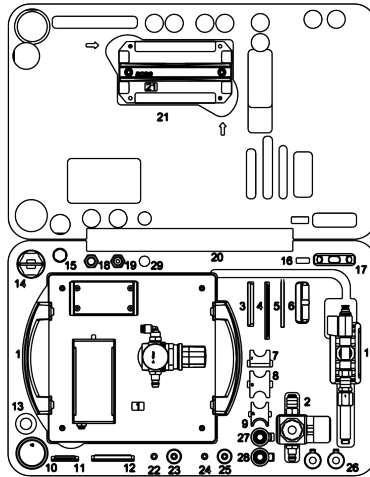

If this equipment is used for pressure test of the fixture, the following values of pressure have to be kept:

Underpressure test.

300 mbar for 1 minute, pressure fall can be to 10 mbar maximally.

Overpressure test

150 mbar maximally!

5. Operating the fixture at ambient temperatures below 0°C

Design of the iEsprite/iEsprite FS allows its operation at ambient temperature up to -30°C, but you have to take some specific into account before operating the fixture.

1. Fixture is not in Standby mode.

iEsprite/iEsprite FS - ambient temperatures from 0°C to -10°C.

The fixture can be switched off but after powered it on, fixture reset can be delayed in range of 0 - 30 minutes depending on ambient temperature (max. delay is at low ambient temperature). This delay is caused by heating fixture effects on operating temperature. The fixture does not respond to DMX during heating the fixture on operating temperature.

We recommend to switch the fixture on at least 30 minutes before show.

iEsprite/iEsprite FS - ambient temperatures from -11°C to -30°C.

The fixture should be permanently powered on in order to keep operating temperature of fixture's effects. If the fixture is switched off, reset of the fixture will last long time (up to 1 hour depending on ambient temperature) until fixture effects reach their operating temperature.

2. Fixture is in Standby mode.

If the fixture is switched to Standby mode (fixture has to be connected to mains), the fixture keeps internal temperature on a level suitable for operation of fixture's effects without delay, heating up of the fixture inside is done automatically.

6. Standby mode

The fixture can be switched to Standby mode by means of web interface REAP or DMX command (channel Power/Special functions, DMX value 6).

Standby mode can be cancelled by means of web interface REAP, DMX command (channel Power/Special functions, DMX value 7) or by switching the fixture off and on.

Standby mode helps conserve power when a fixture is not in use, without fully powering it off. The max. power consumption of the fixture in Standby mode does not exceed 20 W (if the fixture is heated, power consumption is higher). Standby mode is indicated by a notice on the fixture display.

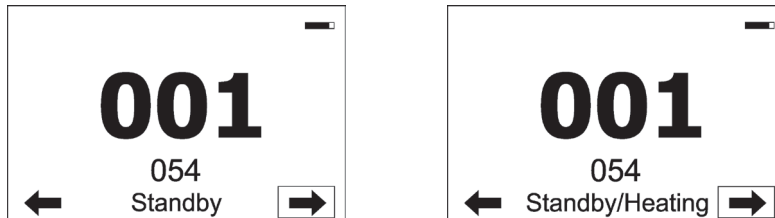

In the Standby mode, the fixture display is functional and can be used for setting of the fixture, but all motors and fans are deactivated, light output is closed.

As the fixture motors are deactivated, the fixture does not respond to DMX values controlling effects but the channel Power /Special functions can be used for fixture settings.

The fixture in Standby mode provides information for RDM and REAP and also can be set its behaviour by means of the RDM and REAP.

Main benefits of Standby mode:

- there is not time delay of fixture reset at ambient temperatures below 0°C.
- By means of REAP user has current information about fixture (settings, temperatures, state of desiccants in the fixture arm).

7. Remotely controllable functions

Colour wheel 1

This wheel contains five dichroic filters + open. The colour wheel can be positioned between two adjacent colours in any position. It is also possible to rotate the colour wheel continuously at different speeds ("Rainbow effect" in both directions).

Colour wheel 2

This wheel contains one multicolour filter, two dichroic filters and two CRI filters (80, 90) + open. The colour wheel can be positioned between two adjacent colours in any position. It is also possible to rotate the colour wheel continuously at different speeds ("Rainbow effect" in both directions).

CMY+CTO colour mixing system

The CMY color mixing system is based on graduated cyan, magenta, and yellow colour filters. A continuous range of colors may be achieved by varying the amount of each filter from 0 to 100%.

Effect wheel

The wheel rotates in both directions with variable speed which creates wide spectrum of graphic effects.

Gobo wheels

The fixture includes static gobo wheel with 9 gobos and rotating gobo wheel with 7 glass gobos rotating in both directions, indexable, replaceable "SLOT&LOCK" system.

Prisms

The fixture includes two rotating prisms: 6-facet linear prism and 6-facet circular prism. Each prism rotates in both directions at different speeds. The 6-facet linear prism is indexable.

Pan/Tilt

Fast pan/tilt movement due to built-in electronic motion stabilizer (EMS). The electronic motion stabilizer ensures precise position of the fixture's head during its movement and reduces its swinging when the truss shakes.

Pan /Tilt movement range: 0-540°/0-265°.

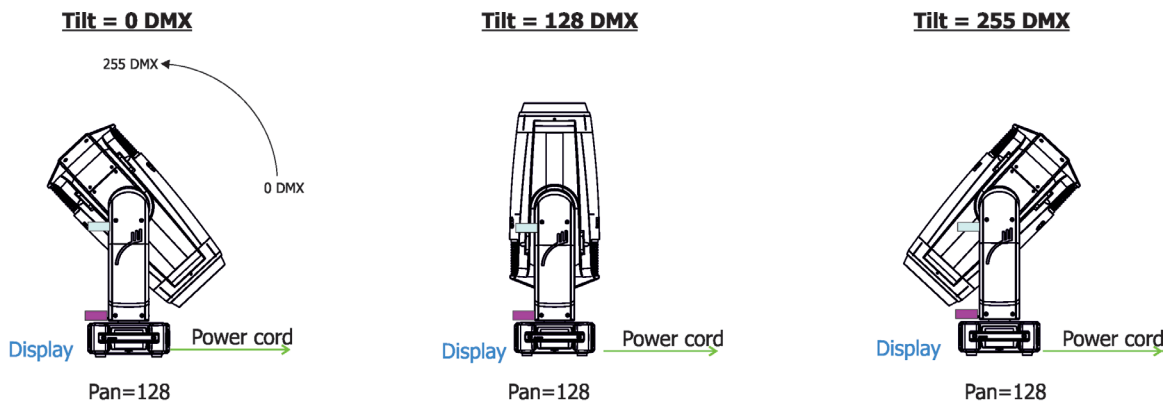

Tilt movement range: 265° Pan movement range: 540°

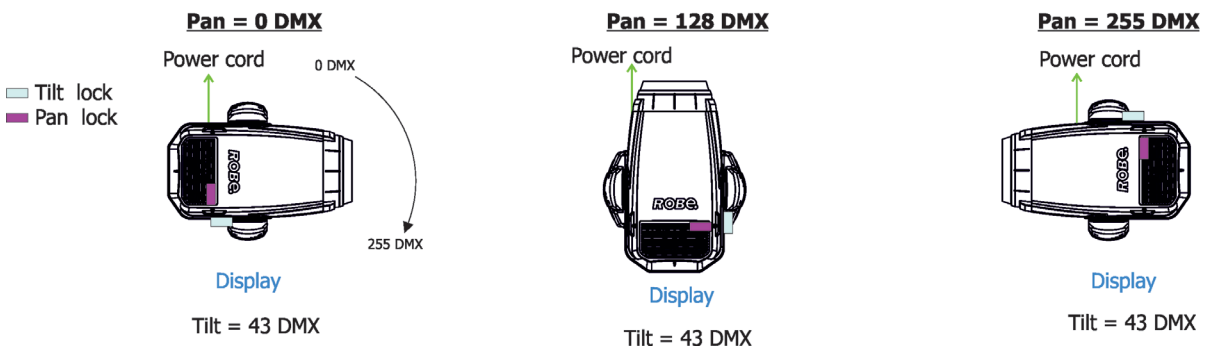

Framing system

Framing system consists of four framing shutters. There is individual control of each shutter blade position and angle, together with rotation of the complete framing module. As well as providing a sharp precise or soft frame for the projected image.

Framing system orientation:

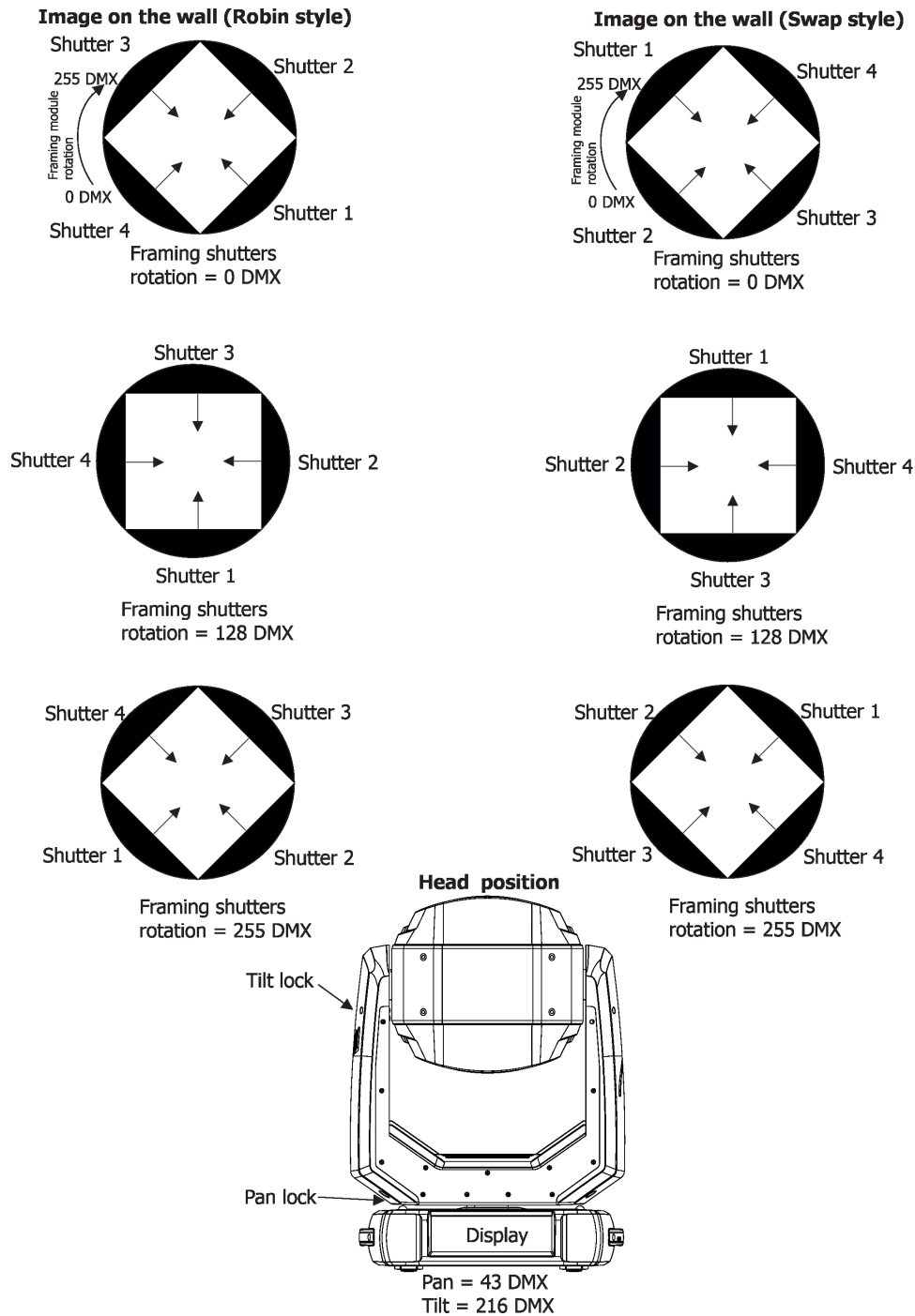

Frost

Two frost filters (light 1° and medium 5°) provide variable frost for fine frosting. The medium frost is replaceable.

Iris

Motorized adjustable iris, wide range of variable pulse effects.

Zoom

Motorized zoom unit enables zoom 3° - 57° (standard optical range and 0.6° - 2° (long throw mode)).

Focus

Motorized focus allows to focus beam from approx. 2 meters to infinity.

7.1 Long throw mode



The Long throw mode is activated when the channel Rotating Gobo wheel is set at 14-16 DMX or 38-40 DMX. If you now use the iris for beam narrowing, a full light power from the LED light source will be utilized without any limitation.

8. Control menu map

Default settings=**Bold print**

Tab	Level 1	Level 2	Level 3	Level 4	Level 5	Level 6	
Addressing	Settings	DMX Address	001-512				
	DMX Preset channels	Pan					
		:					
		Dimmer Fine					
	Ethernet Settings	Ethernet Mode	Disable				
			ArtNet				
			gMAI				
			gMA2				
			sACN				
		Ethernet To DMX	Off , On				
		IP Address/Net Mask	Default IP Address				
			Custom IP Address				
			Net Mask				
		ArtNet Universe	0-255				
		MANet settings	MANet/II Universe	01-256			
			MANet Session ID	01-32			
		sACN Settings	sACN Universe	00001-32000			
	Information	Fixture Times	Power On Time	Total Hours			
				Resetable Hours			
Fixture Temperatures		LEDs Temperatures	Cur.rent				
			Maximum NonRes..				
			Maximum Res..				
		Driver Temperature	Cur.rent				
			Maximum NonRes..				
			Maximum Res..				
		Base Temperature	Current				
			Maximum NonRes.				
			Maximum Res.				
		RAINS Status					
		Sensor s Info					
		DMX Values	Pan				
			:				
			Dimmer Fine				
		Wireless State	Signal Quality				
			Unlink Wireless Adapter				
		Power Channel state					
		Software Versions	Display System				
			Module M				
		Module L					
		Module O					
		Module F-A					
		Module F-B					
		Module G					
		Module FR					
		Module C1					
		Module C2					
		Module DL					
		Wireless					
	Product IDs	Mac Address					
		RDM UID					

Tab	Level 1	Level 2	Level 3	Level 4	Level 5	Level 6
		RDM Label				
	LED Module info	First Module Assembly				
		Actual Module Info				
		Assembly History				
		Intensity History				
	LED Modules History					
	View Logs	Fixture Errors				
		Fixture States	Power On			
			Power Off			
		Fixture Position				
		Fixture Temperatures	LEDs Temperature			
			Driver Temperatures			
			Base Temperatures			
		Sensor Logs				
		Pressure Test Log				
Personality	DMX Preset channels	Pan				
		:				
		Dimmer Fine				
		View Selected Preset				
	DMX Input	Wired				
		Wireless				
		Wireless In/XLR Out				
	Pan/Tilt Settings	Pan Reverse	Off, On			
		Tilt Reverse	Off, On			
		Pan/Tilt Feedback	Off, On			
		Pan/Tilt mode	Time			
			Speed			
	Static Pan/Tilt Reset	Off, On				
	Pan/Tilt Speed	Max				
		Reduced				
	Pan/Tilt EMS	Off, On				
	Follow Spot Mode	Off				
		Soft				
		Medium				
		Hard				
	Pan/Tilt Limitation	Pan Min. Value	0-255			
		Pan Max. Value	0-255			
		Tilt Min. Value	0-255			
		Tilt Max. Value	0-255			
	Blackout Settings	Blackout During M.C.	Off, On			
		Blackout while:	Pan/Tilt moving	Off, On		
			Colour Wheel Moving	Off, On		
	Frequency Setup	300 Hz				
		600Hz				
		1200Hz				
		2400Hz				
		Frequency Adjust				
	Init Effect Positions	Pan	0-255			
		:				
		Dimmer Fine	0-255			
	Reset Effect Positions					
	Screen Settings	Display Intensity	1-10			
		Screen Saver Delay	Off -10min.			
		Display Orientation	Normal			

Tab	Level 1	Level 2	Level 3	Level 4	Level 5	Level 6
			Inverted			
			Auto			
	Temperature Unit	°C, °F				
	Fan Settings	Fan mode	Auto			
			High			
			Quiet			
		Quiet-Blackout Fan Off	Off, On			
	Dimmer Curve	Linear				
		Square law				
		Super Square Law				
	Gobo Indexing	Max. Speed & ShortCut				
		Follow Speed & Direction				
		Max. Speed & Follow Dir.				
	Date & Time Settings					
	Focus Tracking	Off, On				
	Framing Shutters mode	Robin style				
		Swap style				
	Default Settings					
	Password Protection	Off, On				
	Reset Web Password					
Manual Control	Reset Functions	Total System Reset				
		Pan/Tilt reset				
		Color System Reset				
		Gobo/Eff. Wh. Reset				
		Optics/Prism/Frost Res.				
		Iris/framing Sh. Reset				
	Manual Effect Control	Pan	0-255			
		:				
		Dimmer Fine	0-255			
Stand -Alone	Test Sequences	Dynamic Mode				
		Static Mode	Pan	0-255		
			Tilt	0-255		
			Zoom	0-255		
			Focus	0-255		
	Preset Playback	None				
		Test				
		Program				
	Play Program					
	Edit Program	Start Step	1-80			
		End Step	1-80			
		Edit Program Steps	Step 1	Pan	0-255	
			:	:		
			:	Dimmer Fine	0-255	
			:	Step Time	0-25,5 sec.	
			Step 80	Pan	0-255	
				:		
				Dimmer Fine	0-255	
				Step Time	0-25,5 sec.	
Service	Pressure Test					
	Adjust DMX Values	Pan	0-255			
		:				
		Dimmer Fine	0-255			
	Calibrations	Calibrate Effects	Pan	0-255		

Tab	Level 1	Level 2	Level 3	Level 4	Level 5	Level 6
			Tilt	0-255		
			Effect Wheel	0-255		
			Rot. Gobo Wheel	0-255		
			R. Gobo Index 1	0-255		
			:	:		
			R. Gobo Index 7	0-255		
			Static Gobo	0-255		
			Colour Wheel 1	0-255		
			Colour Wheel 2	0-255		
			Prism 1	0-255		
			Prism 2	0-255		
			Zoom	0-255		
			Focus	0-255		
			Iris	0-255		
			Frost 1/1	0-255		
			Frost 1/2	0-255		
			Frost 2/1	0-255		
			Frost 2/2	0-255		
			Fr. Shutters rot.	0-255		
			Fr. Shutter 1 Move	0-255		
			Fr. Shutter 1 Swiv	0-255		
			Fr. Shutter 2 Move	0-255		
			Fr. Shutter 2 Swiv	0-255		
			Fr. Shutter 3 Move	0-255		
			Fr. Shutter 3 Swiv	0-255		
			Fr. Shutter 4 Move	0-255		
			Fr. Shutter 4 Swiv	0-255		
		Calibrate Fr. Shutters	Fr. Shutters rot.			
			Fr. Shutter 1 Move	0-255		
			Fr. Shutter 1 Swiv	0-255		
			Fr. Shutter 2 Move	0-255		
			Fr. Shutter 2 Swiv	0-255		
			Fr. Shutter 3 Move	0-255		
			Fr. Shutter 3 Swiv	0-255		
			Fr. Shutter 4 Move	0-255		
			Fr. Shutter 4 Swiv	0-255		
		Calibrate Fr. Hysteresis	Framing Lamella 1	0-8		
			Framing Lamella 2	0-8		
			Framing Lamella 3	0-8		
			Framing Lamella 4	0-8		
		CalibrateCMY Offsets	Cyan	0-255		
			Magenta	0-255		
			Yellow	0-255		
			CTO	0-255		
		Calibrate Pan/Tilt EMS				
		Calibrate Pan/Tilt Reset				
		Load Default Calibrations				
	Rotating Gobos Change	Gobo Carousel 1	G1-Mg			
			G2			
			:			
			G7			
			Gobo Offset	0-255		
	LEDs Measure					
	Update Software					



9. Control menu

The Robin iEsprite LTL is equipped with the QVGA screen with battery backup and four control buttons which allow you to set the fixture's behaviour according to your needs, obtain information on its operation, test its various parts and program it, if it has to be used in a stand-alone mode. The fixture supports NFC (Near-Field Communication).













NFC interface and control buttons on the front panel



Control buttons on the front panel:

-  - [ESCAPE] button used to leave the menu without saving changes.
-  - [NEXT] , [PREV] buttons for moving between menu items and symbols, adjusting values.
-  - [ENTER/Display On] button used to enter the selected menu item and to confirm adjusted value. If the fixture is disconnected from mains, the button switches the screen on (for a while).

Icons used in the screen menu:

-  - [back arrow] used to move back to the previous screen (menu).
-  - [up arrow] used to move up on the previous page.
-  - [down arrow] used to move down on the next page.
-  - [confirm] used to save adjusted values, to leave menu or to perform desired action.
-  - [cancel] used to leave menu item without saving changes.
-  - [confirm+copy] used to save adjusted values and copy them to the next prog. step.
-  - [warning icon] used to indicate some error which has occurred in the fixture.
-  - [Ethernet] used to indicate Ethernet connected.
-  - [menu rotation] used to rotate menu 180 degrees from current orientation.
-  - [slider control] used to recall slider system for setting desired value.
-  - [keyboard control] used to recall keyboard system for setting desired value.
-  - [QR code] used to show QR code for RDM UID of the fixture and LED engine serial number.

The menu page displays icons for each function that you can perform from the screen. After switching the fixture on, the screen shows the screen with the ROBE logo. Type of used LED engine in the fixture is displayed on the top line of the screen.

XP-type of LED engine used in the fixture.

-20% is a drop of max. light intensity set by the channel "Max. light intensity indication and setting".

Note: drop 0-5% is not signaled.

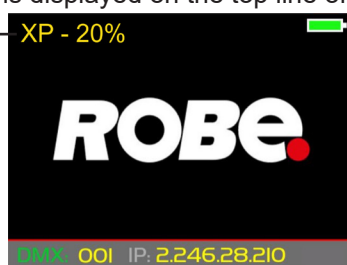

Battery indication

XP - Extra Performance Engine for maximum light output and optimal colour characteristics.
HCF - High Colour Fidelity Engine for the best light quality and colour reproduction.

The type of used LED engine is displayed if the fixture is disconnected from power as well.

The green icon at the top right corner of the screen indicates the level of the display battery charging. If the whole icon is green, the battery is fully charged while the red icon indicates exhausted battery. The battery charges during fixture operation, its charging lasts cca 6 hours.

We recommend that the fixture should be in operation at least 7 hours per week to keep the battery fully charged. If you switch the fixture on and this screen will not appear till 1 minute, switch the fixture off and on again. If the screen lights, the battery is exhausted. In case the screen still does not light, the battery is faulty.

This is also indicated by an error message "Faulty battery" and if such an error message appears the battery should be replaced immediately. The lifetime of the battery is highly dependent on ambient temperature (and consequently on base temperature). If the maximum ambient temperatures (as recorded and displayed in menu: Information -> Fixture Temperatures -> Ambient Temperature -> Maximum NonRes.) are kept within the specified limits, the battery should last for at least two years. Should the ambient temperatures exceed the specified maximum temperature, the lifetime of the batteries could be considerably shortened even up to just one year or less and also result in physical damage (battery leakage) or unreliable fixture functions.

Damage caused by batteries failed due to exceeded maximum ambient temperature cannot be claimed under warranty terms.

Press the [ENTER/Display On] button to display the initial screen with current DMX address:



Press the [ENTER/Display On] button to enter the "Address" menu.

An item may be selected from a screen by pressing the [NEXT] or [PREV] buttons to scroll through list items.

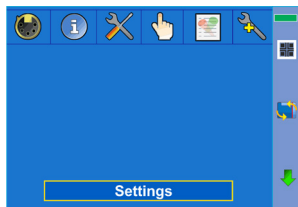

Icon for QR codes
 Use [NEXT], [PREV]
 buttons for moving
 between QR codes

QR code for RDM UID of
 the fixture.



QR code for serial number
 of LED engine in the fixture.



(pictures for illustration only)

Before first fixture operation, set current date and time in the menu "Date & Time Settings" (menu path: Personality--> Date & Time Settings).

As the fixture can be operated at wide range of ambient temperatures, suitable environment has to be maintained in inside of the fixture. The following messages under DMX address inform you about fixture status.



The fixture is waiting for finishing all reset procedures.
 Fixture does not respond to DMX.

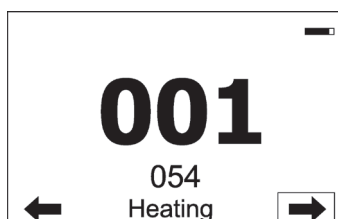

The fixture is waiting for reaching operating temperature of the fixture
 inside (inside temperature is below 0°C).
 Fixture does not respond to DMX.

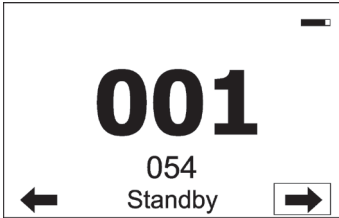

The fixture is in standby mode.
 Fixture effects does not respond to DMX, but display is active. Fixture sends its statuses and recorded physical values (temperature, humidity, pressure) to the REAP.

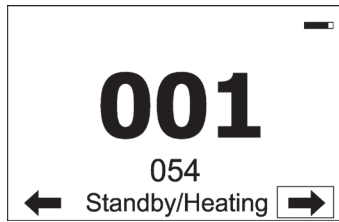

The fixture is in standby mode and inside of the fixture is heated (ambient temperature is below 0°C).
 Fixture does not respond to DMX, but display is active. Fixture sends its statuses and recorded physical values (temperature, humidity, pressure) to the REAP.

Locking/unlocking the screen.

To lock the screen, display the screen with ROBE logo, touch the [ESCAPE] button and slide your finger clockwise in a circular track of 360° across buttons [ESCAPE] --> [NEXT] --> [ENTER/Display On] --> [PREV]--> [ESCAPE]. The sign "Buttons are locked" will appear on the screen. If this sign will not appear, repeat finger sliding again with a different speed.



To unlock the screen, touch the [ESCAPE] button and slide your finger clockwise in a circular track of 360° across buttons [ESCAPE] --> [NEXT] --> [ENTER/Display On] --> [PREV]--> [ESCAPE].

The sign "Buttons are locked" will disappear from the screen. If this sign still remains on the screen, repeat finger sliding again with a different speed.



9.1 Tab " Address"



DMX Address - Select the menu to set the DMX start address.

Blinking DMX address means that the fixture is either not receiving DMX data or that the set DMX address is higher than allowed, exceeding the DMX footprint of the set DMX mode.

DMX Preset Channels - The menu item shows order of control channels

Ethernet Settings - The menu allows all needed settings for the Ethernet operation

Ethernet Mode

Disable - The option disables Ethernet operation.

Artnet - Fixture receives Artnet protocol

gMAI - Fixture receives MANet 1 protocol

gMA2 - Fixture receives MANet 2 protocol

sACN - Fixture receives sACN protocol

Ethernet To DMX - Fixture receives protocol from the Ethernet input and sends DMX data to its DMX output (fixture works as an "Ethernet/DMX converter", next fixture can be connected to its DMX output and you can build a standard DMX chain by connecting another fixtures. Only one fixture has to be connected to the Ethernet.

IP Address/Net Mask - Select this menu to set IP address. IP address is the Internet protocol address. The IP uniquely identifies any node (fixture) on a network.

There cannot be 2 fixtures with the same IP address on the network!

Default IP Address -Preset IP address, you can set up only first byte of IP address (2 or 10) e.g. **002**.019.052.086.

Custom IP Address - The option enables to set up all bytes of IP address.

Net Mask - The option enables to set up all bytes of Net Mask.

ArtNet Universe - Use this item to set a Universe (0-255). The Universe is a single DMX 512 frame of 512 channels.

MANet Settings - Use this menu to set parameters for MANet operation.

MANet Universe I/II - The value of this item can be set in range 1-256.

MANet Session ID - The value of this item can be set in range 1-32.

sACN Settings - Use this menu to set parameters for sACN operation.

sACN Universe - The value of this item can be set in range 1-32000.

9.2 Tab "Information"



Fixture Times - The menu provides readouts of fixture and LED module operation hours.

Power On Time - Select this menu to read the number of fixture operation hours.

Total Hours - The item shows the total number of the operation hours since the Robin iEsprite LTL has been fabricated.

Resettable Hours - The item shows the number of the operation hours that the Robin iEsprite LTL has been powered on since the counter was last reset.

In order to reset this counter to 0, touch the text box next to the item "Resettable Hours:"

Fixture Temperatures - The menu is used to view temperatures of the fixture's inside.

LEDs temperature - The menu shows temperature on the LED PCB in the light source.

Current - A current temperature of the LED PCB.

Maximum NonRes. - A maximum temperature of the LED PCB since the fixture has been fabricated.

Maximum Res. - A maximum temperature of the LED PCBs since the counter was last reset.
In order to reset some counter to 0, touch desired text box under item "Max.Res."

Driver Temperature - The menu shows temperature on the LEDs control PCB in the fixture head.

Current - A current temperature on the LEDs control PCB.

Maximum NonRes. - A maximum temperature on the LEDs control PCB since the fixture has been fabricated.

Maximum Res. - A maximum temperature on the LEDs control PCB since the counter was last reset.

In order to reset this counter to 0, touch the text box next to the item "Maximum Res."

Base Temperature - The menu shows temperature on the display PCB in the fixture base.

Current - A current temperature on the display PCB.

Maximum NonRes. - A maximum temperature on the display PCB since the fixture has been fabricated.

Maximum Res. - A maximum temperature on the display PCB since the counter was last reset.

In order to reset this counter to 0, touch the text box next to the item "Maximum Res."

RAINS Status - The menu item gives you information about environment in the fixture.

RAINS (Robe Automatic Ingress Neutralization System) manages humidity, temperature and pressure control using an active monitoring system to automatically remove any moisture detected within the fixture and provides permanent monitoring to ensure peak performance of the fixture.

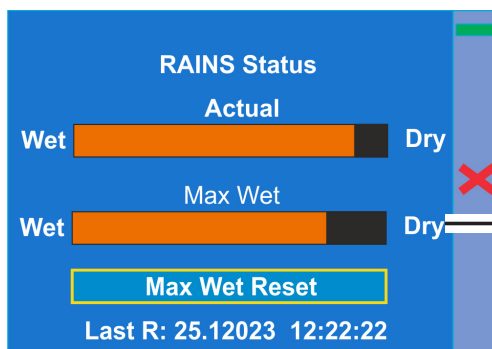

Silica gel desiccants in the fixture arm

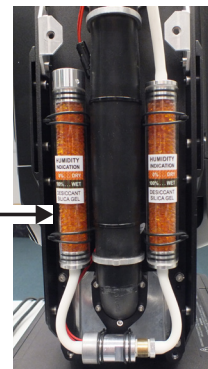

The bar chart **Actual** informs you about current humidity in the fixture. The bar chart changes depending on humidity, temperature and pressure in the fixture. The bar chart depends on current conditions in the fixture and can be different at start of fixture operation, after 10 minutes of its operating, after closing fixture dimmer etc.

The bar chart **MAX WET** informs you about maximum humidity achieved in the fixture since the chart was last reset. The bar chart also informs you about saturation of silica gel desiccants in the fixture arm with water and is deciding indicator for their checking and replacement.

The option **MAX WET reset** resets the bar chart MAX WET. Date and time of last reset is displayed below the option.

Examples of RAINS statuses:

Dry desiccants in the fixture arm

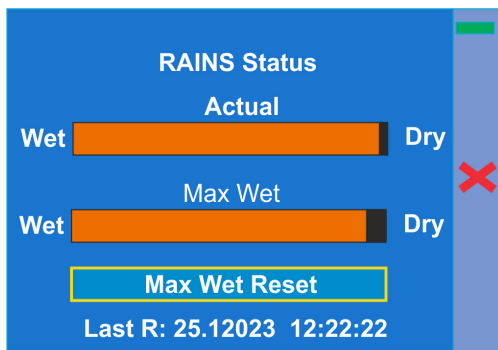

Desiccants in the fixture arm partially saturated with water

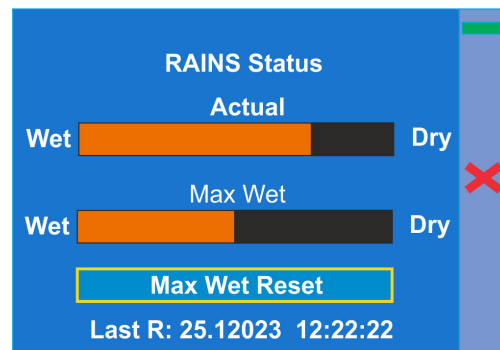

Desiccants in the fixture arm fully saturated with water

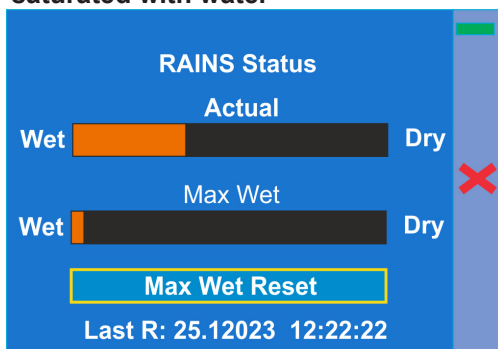

Silica gel desiccants in the fixture arm are saturated with water and should be replaced.

After replacing them, reset the item MAX WET.

It is not necessary to replace silica gels desiccants in plastic boxes in the fixture head and base. These desiccants should be checked (and replaced if it is needed) at removing head or base covers, e.g. at gobo replacement or some service intervention.

Sensors Info - The menu items shows you current conditions in the fixture head (at pressure sensor): temperature, relative humidity and pressure.

Wireless State - The menu serves for reading of the wireless operation status.

Unlink Wireless Adaptor - The item serves for unlinking the fixture from a DMX transmitter.

If the wireless module is not installed in the fixture, message "Wireless Module Not Installed" will appear.

Power Channel State - Select this item to see current setting of the functions, which can be set by menu items in "Personality" as well as by DMX command at channel "Power/Special functions".

Colour Functions State - Select this item to see current setting of the colour functions, which can be set by menu items in "Personality" as well as by DMX command at channel "Colour functions".

Software Version - Select this item to read the software version of the fixture processors:

Display System - A display processor on the display board in the fixture base

Module M - a Pan/Tilt processor

Module L - a LEDs control processor

Module O - a Focus/Zoom/Prism control processor

Module F-A - a Framming shutters control processor

Module F-B - a Framming shutters + Iris control processor

Module G - a Rot. gobo/Static gobo wheel control processor

Module FR - a Frost control processor

Module C1 - a Colour wheel 1 control processor

Module C2 - a Colour wheel 2 control processor

Module DL - a Data Logger control module

Wireless - a wireless DMX/RDM module

Product IDs - The menu is used to read the MAC Address ,RDM UID and RDM Label.

LED Module Info - Use this menu to read LEDs module information.

First Module Assembly - Use the item to read initial information about the LEDs module installed in the fixture. The fixture has to be connected to mains to read the values in the menu items.

Serial Number/ Device UID - a serial number of the LEDs module/RDM UID of the fixture.

Installation Date/Time - a date/time of the first installation of the LEDs module to a some iEsprite LTL device.

Intensity - an original intensity of the LEDs module in percentages (100%).

LEDs On Time Total/Adaptive - Total: a total time of the LEDs module operation during which the dimmer intensity was > 0%.

Adaptive: a relative time of the LEDs module operation during which the dimmer intensity was > 0% (e.g. if dimmer = 50% for one hour, the adaptive time is 0.5 hour, if dimmer = 100% for one hour, the adaptive time is 1 hour).

Actual Module Info - Use the item to read current information about the LEDs module installed in the fixture.

Serial Number/ Device UID - a serial number of the LEDs module/RDM UID of the fixture.

Measurement Date/Time - a date/time of running the procedure "LEDs Measure" in the tab Service.

Intensity - the item shows a light intensity of the LEDs module measured after running the procedure "LEDs Measure" in the tab Service. The light intensity is displayed in percentages in relation to the initial intensity of the new LEDs module (initial intensity=100%).

LEDs On Time Total/Adaptive - Total: a total time of the LEDs module operation during which the dimmer intensity was > 0%.

Adaptive: a relative time of the LEDs module operation during which the dimmer intensity was > 0% (e.g. if dimmer = 50% for one hour, the adaptive time is 0.5 hour, if dimmer = 100% for one hour, the adaptive time is 1 hour).

Assembly History - Use the item to read a history of the LEDs module installed in the fixture (its serial number, RDM UID of fixture at which was installed and date/time of installation).

Up to 31 records can be saved in the menu item.

Intensity History - Use the item to read a history of light intensity of the LEDs module installed in the fixture.

Serial Number/ Device UID - a serial number of the LEDs module/RDM UID of the fixture.

Measurement Date/Time - a date/time of running the procedure "LEDs Measure" in the tab Service.

Intensity - the item shows a light intensity of the LEDs module measured after running the procedure "LEDs Measure" in the tab Service. The light intensity is displayed in percentages in relation to the initial intensity of the new LEDs module (initial intensity=100%) .

Up to 31 records can be saved in the menu item.

LED Modules History - Use the item to read a history of the LEDs modules installed in the fixture (their serial numbers and date/time of installation).

Up to 31 records can be saved in the menu item.

View Logs - Use this menu to read fixture's data which have been recorded during fixture operation. This collected data allows easier troubleshooting.

Fixture Errors - Use this menu to read fixture errors which have occurred during fixture operation.

Fixture States - In the menu are recorded fixture states as power on and power off.

Fixture Positions - In the menu are recorded installation positions of the fixture:

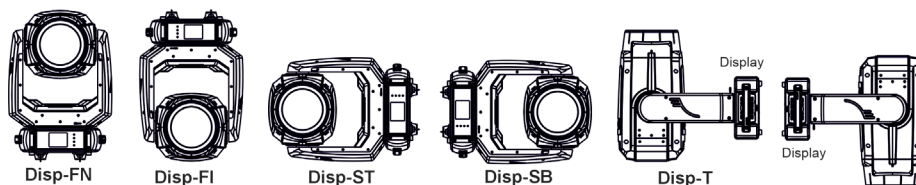

Fixture Temperatures - In the menu are recorded temperatures which have exceeded defined levels.

Sensor Logs - In the menu item are recorded physical values in the fixture: temperature, relative humidity and pressure.

Pressure Test Log - In the menu item are recorded values related to executed pressure tests: date and time, temperature, pressure difference, duration of pressure test and its result.

Note: The log buffer can contain max. 8000 records. If the buffer is full, old data will be overwritten.

9.3 Tab "Personality"



DMX Preset Channels - The menu item shows order of control channels

DMX Input- Use the menu to select mode of DMX signal receiving.

Note: if the fixture is not connected to mains, warning "Not Available In Offline Mode" will appear on the screen.

Wired - DMX signal is received by means of the standard DMX cable.

Wireless - DMX signal is received by means of the inbuilt wireless module.

Wireless In/XLR Out- the fixture receives wireless DMX and sends the signal to its wired DMX output.

The fixture behaves as " Wireless/Wired" adapter.

The options "Wired" and "Wireless" are also stated in DMX chart (channel Power/Special functions).

Note. If the wireless module is not installed in the fixture, the following message will appear:

"DMX Input Set to Wired

Wireless Module Missing"

If the fixture is not connected to mains, the message "Not Available In Offline Mode" will appear after entering the menu DMX Input. To enter this menu, the fixture has to be connected to mains.

Pan/Tilt Settings - Use the menu set behaviour of both pan and tilt movements.

Pan Reverse - The item allows to invert pan movement.

Tilt Reverse - The item allows to invert tilt movement.

Pan/Tilt Feedback - The item allows to return the moving head to the required pan/tilt position after changing the position by an external force if this option is set on.

Note. Be careful, the Pan/Tilt Feedback should be permanent On, the option Off is not suitable for standard operation and the head of the fixture can be damaged!

Pan/Tilt mode - Use this menu to set the mode of the pan/tilt movement

Time mode – The pan and tilt will move with different speeds and they will come at the same time to the end point of their tracks (pan and tilt use their optimal speeds).

Time of the pan/tilt movement (25.5 sec. max.) is set by the channel "Pan/Tilt speed, Pan/Tilt time".

Speed Mode - Both Pan and tilt will move with the same speed as adjusted at the channel "Pan/Tilt speed, Pan/Tilt time".

Static Pan/Tilt Reset - If the item is on, the pan/tilt reset is without head movement.

If the item is off, fixture's head uses entire pan track and entire tilt track for pan and tilt reset (standard behaviour of fixtures without MAPS).

The function is also available by DMX commands (channel Power/Special functions, DMX values 210-211).

Set value by DMX command is saved in the fixture until it is changed.

Setting of this function also affects the behaviour of the menu item "Calibrate Pan/Tilt reset" in the tab Service (Service-->Calibrations--> Calibrate Pan/Tilt reset).

Pan/Tilt Speed - The item allows you to select speed of pan/tilt movement.

Max. - Maximum speed of the pan/tilt movement. The base (not the head) of the fixture must be in a horizontal position only.

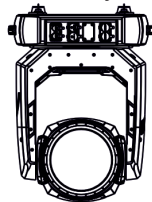
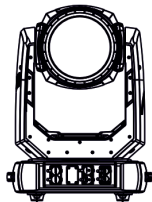

Max. or Reduced Pan/Tilt speed

Reduced - Reduced speed of the pan/tilt movement. The reduced speed is mainly intended for "sideways" rigging of the fixture, when the base (not the head) of the fixture is in a vertical position.

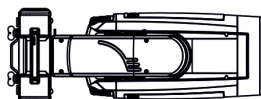
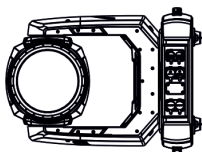

Reduced Pan/Tilt speed only

The option Pan/Tilt Speed is also available by DMX command (channel Power/Special Functions, DMX range 36-39)

Pan/Tilt EMS - Built-in electronic motion stabilizer ensures precise position of the fixture's head during its movement and also reducing its swinging when the truss shakes.

Follow Spot Mode - If the function is activated, the pan/tilt motors perform on lower power and the head position can be controlled manually. You can choose from three levels of the pan/tilt "consistency": soft, medium and hard. Note: reset of pan/tilt will not be executed if the fixture is in the Follow Spot Mode.

Pan/Tilt Limitations - The function allows you to reduce range of pan and tilt movement by setting limits for both movements.

Pan Min. Value - Minimum pan movement value.

Pan Max. Value - Maximum pan movement value.

Tilt Min. Value - Minimum tilt movement value.

Tilt Max. Value - Maximum pan movement value.

If receiving DMX values are out of set limits, the fixture will not respond to them.

Example: Pan Min. Value=40 DMX, Pan Max. Value=120 DMX, the head will move in pan range of 40-120 DMX. Values under 40 and above 120 will not be used.

At reset of the head without connected DMX (if Pan/Tilt brake=Off), the pan movement of the head will stop in the value 120 DMX. After cancelling the pan movement limitation, the head will move to the value 128 DMX. (Standard pan and tilt positions after reset of the head without DMX are 128 DMX, unless otherwise set in the menu Init Positions).

Blackout Settings - Use the menu if you need to close the light output under certain conditions which are described below:

Blackout During MC - Blackout during movement correction. Set this option On if you wish to close light output during the time when the head goes to its correct position from which has been changed by an external force.

Active Blackouts - Use this menu if you wish to close the light output during effect changes.

Pan/Tilt Moving - The menu item enables to close light output while the pan/tilt DMX values are changing.

Colour Wheel Moving - The menu item enables to close light output while colour wheel is moving.

Frequency Setup - The function allows you to set the PWM (Pulse Width Modulation) output frequency of LEDs to 300Hz, 600Hz, 1200Hz or 2400Hz.

Frequency Adjust - The menu item allows you fine adjustment of the LED frequency around selected frequency.

Init Effect Positions - Use the menu to set all effects to the desired positions at which they will stay after switching the fixture on without DMX signal received.

Reset Effect Positions - Use the menu to set the menu item "Init Effect Positions" to default values.

Screen Settings - Use this menu to change the touch screen settings.

Display Intensity - The item allows to control the intensity of the screen (1-min., 10-max.).

Screen saver Delay - The item allows you to keep the screen on or to turn it off automatically after 1-10 minutes after last touch (or pressing any button on the control panel).

Display Orientation - The menu allows to change display orientation.

Normal - Standard display orientation if the fixture is placed horizontally (e.g. on the ground).

Inverted - Inverted orientation (needed if the fixture is hanging on the truss).

Auto - The option activates a gravitation sensor for automatic screen orientation.

Note: **Auto** option is set as default. You change the display orientation by touching the icon  on the display, and the option set in the "Display Orientation" menu is temporarily overridden.

Temperature unit - Use the menu item to change temperature unit from °C to °F.

Fan Settings - Use the menu to set fans operation mode.

Fan Mode - Use the menu to set the fixture fans to max. power mode (option "**High**") or to the auto-control mode (option "**Auto**"). The third option "**Quiet**" allows you to set desired fan noise. The light output of the fixture is reduced at low speeds of fans and the High-power Mode is deactivated.

Quiet - Blackout Fan Off - The menu item allows you to stop all fans in the fixture (option "**On**") when its light output is closed (shutter in range of 0-31 DMX or dimmer in 0 DMX).

Dimmer Curve - Use the menu to select desired dimmer curve: **Linear**, **Square Law** or **Super Square Law**.

Gobo Indexing - The following three options define transition from gobo rotation to gobo indexing.

Max. Speed & Shortcut - Gobo goes from its rotation to desired indexed position with max. speed and via shortest track.

Follow Speed & Direction - Gobo goes from its rotation to desired indexed position with current speed and keeps a direction of rotation.

Max. Speed & Follow Dir. - Gobo goes from its rotation to desired indexed position with max. speed and keeps a direction of rotation.

Date & Time Settings - Use this menu to set current date and time for the fixture log system (menu "View Logs"). Set this menu items before first fixture operation.

Focus Tracking - This feature provides automatic sharpness re-adjustment during zoom movement, after an initial sharpness has been set by the operator by setting the focus channel and enabling the FocusTracking. The Focus Tracking feature is done via automatic movement of focus element, taking into account several internal parameters, zoom position being one of them. To utilize the Focus Tracking, make sure to enable the Focus Tracking, set the Zoom to value 200 and adjust Focus to desired sharpness. Then, while keeping Focus value untouched, you can move the Zoom. Fixture will automatically keep the projection at the desired sharpness as much as possible. You can also re-adjust the Focus value over time if needed. When switching between rotating gobo wheel/ static gobo wheel and an empty aperture, the Tracking Focus will adjust the internal parameters, therefore providing desired sharpness by adjusting the Focus might be required. If you use both rotating gobo wheel and static gobo wheel without further adjusting the focus value, rotating gobo wheel will be automatically used for Focus Tracking 's focusing.

Framing Shutters Mode - Use the menu to select desired order of framing shutters movement.

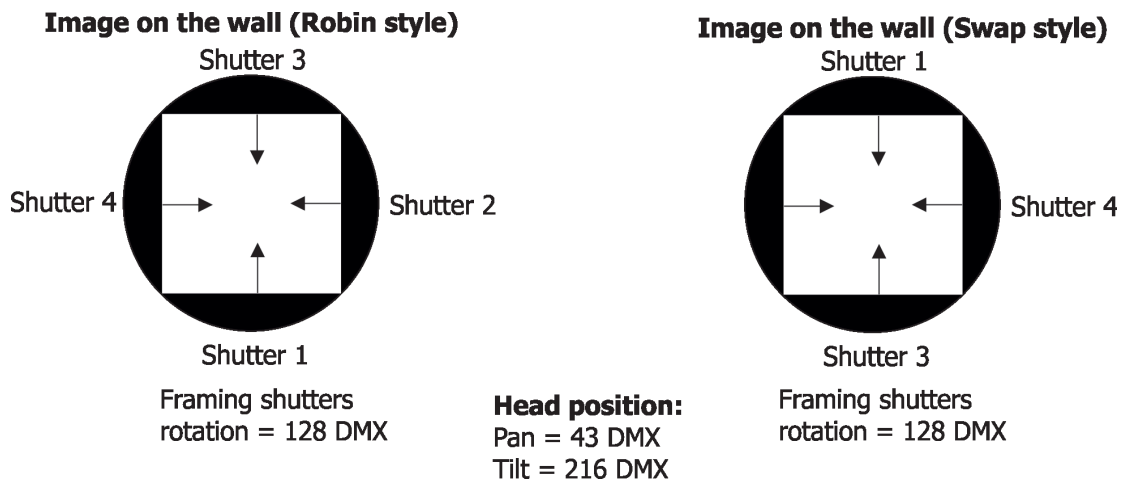

Default Settings - The menu item allows to set all fixture parameters in this menu to the default (factory) values except items "DMX Input".

Password Protection - allows to enter password in order to prevent unauthorized person from changing setting of the fixture. Password is set to 7623 and cannot be changed.

Reset Web Password - The menu item allows you to reset a password for access to the REAP (default password: 2479, user: robe).

9.4 Tab "Manual Control"



Reset Functions - The menu allows to reset the fixture either per function modules or all modules together.

Total System Reset - The item resets all function modules including pan/tilt.

Pan/Tilt Reset - The item resets a pan and a tilt.

Colour System Reset - The item resets colour wheel 1, colour wheel 2 and CMY+CTO system.

Gobo/Eff. Wh. Reset - The item resets static and rotating gobo wheel and an effect wheel.

Optics/Prism/Frost Res. - The item resets a zoom, focus, prism and a frost module.

Iris/Framing Sh. Reset - The item resets an iris module and framing shutters.

Manual Effect control - Use the menu to control all fixture channels by means of the control panel.

9.5 Tab "Stand-alone"



Test Sequences -Use the menu to run a test/demo sequences without an external controller, which will show you some possibilities of using Robin iEsprite.

Dynamic Mode - This mode uses all Robin iEsprite LTL functions including pan/tilt movement and therefore is good for a complete introduction of the fixture.

Static Mode - This mode is suitable for projections on the wall, ceiling or ground without any pan/tilt movement. Adjust the pan, tilt, zoom and focus to desired positions an start test sequences by touching the green ► icon.

Preset Playback - This menu allows you to select the program which will be played in a loop after switching the fixture on (the option is commonly used in a stand-alone operation without an external controller).

None - The option disables "Presetting playback" function.

Test - The option starts the test sequences.

Program - The option starts user program.

Play program - Use the menu to run user program in a loop.

Edit Program - Use the menu to create or to edit user program up to 80 steps.

To edit program:

1. Touch the item "Edit Program Steps".

2. Touch the item "Step 1".

3. From the list of effects touch desired effect and set its value. Browse throw the list by touching the [up arrow] and [down arrow] and set all desired effects.

An item "Step Time" (value of 0-25.5 sec.) is the time during which effects last in the current step

4. Save adjusted effects to the current step by touching the [confirm] or save and copy them to the following step by touching the [confirm+copy]. By touching the text box "Preview" next to the current program step you can view created scene.

5. Repeat the steps 3 and 4 for next program steps.

6. After editing desired program steps, adjust the length of the program by touching the text boxes "Start Step" and "End Step".

Meaning of the icons used in the "Edit Program" menu:



- moves down on the next page



- saves adjusted values and leaves menu



- moves up on the previous page



- saves values to the current step and copy them to the following prog. step



- leaves menu without saving values

9.6 Tab "Service"



Pressure Test - The menu item runs a procedure which checks the IP65 integrity of the fixture. The fixture has to be connected to mains and the head temperature (at pressure sensor) cannot be higher than 55°C. The pressure test lasts about 8 minutes and can be run at earliest 10 minutes after closing light output (shutter closed) of the fixture. The pressure test can be repeated at earliest 2 minutes after last pressure test.

For more details of pressure test please see the chapter Checking the IP65 integrity of the fixture.

Adjust DMX Values - The menu allows you to set all effects to desired positions before fine calibration of the effects .

Calibrations - This menu enables fine calibration of fixture effects and download default calibration values.

Calibrate Effects - The menu allows the fine adjustment of effects.

Pan- a pan position fine adjustment (value range: 0-255)

Tilt - a tilt position fine adjustment (value range: 0-255)

Effect Wheel - an effect wheel position fine adjustment (value range: 0-255)

Rot. Gobo Wheel - a carousel of rotating gobos fine movement (value range: 0-255)

R. Gobo Index 1 - a fine movement of the rotating gobo 1 (value range: 0-255)

R. Gobo Index 2 - a fine movement of the rotating gobo 2 (value range: 0-255)

R. Gobo Index 3 - a fine movement of the rotating gobo 3 (value range: 0-255)

R. Gobo Index 4 - a fine movement of the rotating gobo 4 (value range: 0-255)

R. Gobo Index 5 - a fine movement of the rotating gobo 5 (value range: 0-255)

R. Gobo Index 6 - a fine movement of the rotating gobo 6 (value range: 0-255)

R. Gobo Index 7 - a fine movement of the rotating gobo 7 (value range: 0-255)

Static Gobo - a static gobo wheel fine movement (value range: 0-255)

Colour Wheel 1 - a colour wheel 1 fine movement (value range: 0-255)

Colour Wheel 2 - a colour wheel 2 fine movement (value range: 0-255)

Prism 1/1 - a prism 1 fine movement (value range: 0-255)

Prism 1/2. - a prism1 fine rotation (value range: 0-255)

Prism 2/1 - a prism 2 fine movement (value range: 0-255)

Prism 2/2 - a prism 2 fine rotation (value range: 0-255)

Zoom - a zoom module fine movement (value range: 0-255)

Focus - a focus module fine movement (value range: 0-255)

Iris - an iris fine movement (value range: 0-255)

Frost 1/1 - a light frost fine position movement 1

Frost 1/2 - a light frost fine position movement 2

Frost 2/1 - a medium frost fine position movement 1

Frost 2/2 - a medium frost fine position movement 2

Fr. Shutters.rot- a framing shutters module fine rotation (value range: 0-255)

Fr. Shutter 1 Move - a Fram. lamella 1 fine moving

Fr. Shutter 1 Swiv. - a Fram. lamella 1 fine swivelling

Fr. Shutter 2 Move - a Fram. lamella 2 fine moving

Fr. Shutter 2 Swiv.- a Fram. lamella 2 fine swivelling

Fr. Shutter 3 Move - a Fram. lamella 3 fine moving

Fr. Shutter 3 Swiv. - a Fram. lamella 3 fine swivelling

Fr. Shutter 4 Move - a Fram. lamella 4 fine moving

Fr. Shutter 4 Swiv. - a Fram. lamella 4 fine swivelling

Calibration of the effects via the control board

1. Disconnect DMX controller from the fixture and enter the "Calibrate Effects" menu.
2. Use the [up arrow] and [down arrow] to find "Pan" and touch it to enter the fine effect adjustment screen.
3. Set desired value and save it by touching the [confirm].
4. Repeat steps 2 and 3 for next item
5. After calibrating all effects, touch the [confirm] to save all adjusted values and reset the fixture.

Calibration of the effects via the DMX controller

1. Connect DMX controller to the fixture and enter the "Calibrate Effects" menu.

Calibration protocol:

Effect	Channel
Pan	channel 54
Tilt	channel 51
Ef. wheel	channel 52
Rot. Gobo Wheel	channel 53
R. Gobo Index 1	channel 54
R. Gobo Index 2	channel 55
R. Gobo Index 3	channel 56
R. Gobo Index 4	channel 57
R. Gobo Index 5	channel 58
R. Gobo Index 6	channel 59
R. Gobo Index 7	channel 60
Static gobo	channel 61
Colour wheel 1	channel 62

Effect	Channel
Colour wheel 2	channel 63
Prism 1/1	channel 64
Prism 1/2	channel 65
Prism 2/1	channel 66
Prism 2/2	channel 67
Zoom	channel 68
Focus	channel 69
Iris	channel 70
Frost 1/1	channel 71
Frost 1/2	channel 72
Frost 2/1	channel 73
Frost 2/2	channel 74
Fr. Shutters rot.	channel 75
Fr. Shutter 1 Move	channel 76
Fr. Shutter 1 swiveling.	channel 77
Fr. Shutter 2 Move	channel 78
Fr. Shutter 2 swiveling	channel 79
Fr. Shutter 3 Move	channel 80
Fr. Shutter 3 swiveling	channel 81
Fr. Shutter 4 Move	channel 82
Fr. Shutter 4 swiveling	channel 83

Calibrate Fr. Shutters - The menu serves for factory calibration of framing shutters.

Calibrate Fr. Hysteresis

Framing Lamella 1 - a framing lamella 1 reverse movement (value range: 0-8)

Framing Lamella 2 - a framing lamella 2 reverse movement (value range: 0-8)

Framing Lamella 3 - a framing lamella 3 reverse movement (value range: 0-8)

Framing Lamella 4 - a framing lamella 4 reverse movement (value range: 0-8)

The value set for every framing lamella gives a value at which the lamella reacts to its reverse movement promptly (without movement hysteresis).

Calibrate CMY Offsets - The menu serves for fine calibration of CMY and CTO flags in factory.

Calibrate Pan/Tilt EMS - The menu item allows calibration of the pan/tilt electronic motion stabilizer.

Important: during this calibration any external force must not influence the fixture and the surface at which the fixture stands (or truss if the fixture hangs) has to be without movement, shake, strokes etc.

Calibrate Pan/Tilt Reset - The menu item allows you to calibrate pan and tilt reset. After this calibration, the pan/tilt reset will start automatically. Behaviour of the pan/tilt reset is affected by setting the item "Static Pan/Tilt Reset" (tab Personality -->Static Pan/Tilt Reset). After finishing pan/tilt reset calibration, the following message will appear:

Pan/Tilt Reset
Calibration Process
DONE

The function "Calibrate Pan/Tilt Reset" has to be used in case of changing pan or tilt motor or pan/tilt control PCB (RB3138 in the fixture yoke).

The function "Calibrate Pan/Tilt Reset" also can be start by DMX command (channel Power/Special functions, DMX value 212).

Load Default Calibrations - The item loads default (factory) calibration values.

Rotating Gobos Change - This menu makes changing of rotating gobos in the fixture easier.

Gobo Carousel 1 - The menu allows movement of rotating gobos to the positions suitable for their changing.

G1-Mg - a movement of the gobo 1 (gobo holder with magnet) to the changing position.

G2 - a movement of the gobo 2 to the changing position.

:

G7 - a movement of the gobo 7 to the changing position.

Gobo Offset - a gobo offset setting. The function allows fine swiveling of the gobo holder. The set value is valid for all gobos on the gobo carousel.

LEDs Measure - This menu item runs a procedure which measures a light intensity of the LEDs module installed

in the fixture. This procedure takes about 1 minute (message " LEDs Module Measurement" is displayed on the screen"). During the procedure the fixture does not receive DMX signal, pan/tilt go to 128 DMX, a shutter is open and a dimmer is set at max. light intensity (255 DMX). All effects are taken out from the light beam.

The measured light intensity is recorded in the item Intensity in the menu LED Module Info:

Tab Information --> Actual Module Info --> Intensity

Tab Information --> Intensity History --> Intensity

The light intensity in the menu item Intensity is displayed in percentages in relation to the initial intensity of the new LEDs module (initial intensity=100%).

The LEDs Measure procedure should be run after every change of the LED light source.

Note: The fixture has to be connected to mains in order to run LEDs Measure procedure.

Update software - The menu item allows you to update software in the fixture.

The following items are required in order to update software:

- PC running Windows or Linux or macOS
- DSU file
- Flash cable RS232/DMX, P/N13050624 (if you want to use a serial port of PC)
- Robe Universal Interface or Robe Universal interface WTX (if you want to use an USB port of PC)

After the software updating the fixture will be set to default values.

To update software in the fixture:

1. DSU file is available from Robe web site at WWW.robe.cz.

File with extension zip is intended for Windows (used and tested from XP to W11 on 32/64bit systems).

File with extension tbz is intended for Linux (used and tested on Debian and Ubuntu 32/64bit).

File with extension dmg is intended for macOS (used and tested on OSX up to Sierra) XQuartz required, install it from <https://www.xquartz.org/>

Save the download file to a folder on your computer.

In case that you use windows, extract files in the zip file (e.g. DSU_RobiniEsprite_18100828.zip)

2. Disconnect the fixture from DMX controller.

3. If you use the flash cable RS232/DMX, connect a serial port of your computer with DMX input of the fixture by means of the cable.

If you use the Robe Universal Interface, connect a USB port of your computer with the Robe Universal Interface by means of the USB cable and DMX input of the fixture with the DMX output of the Robe Universal Interface via a DMX cable.

4. Switch the fixture to the update mode (tab "Service" --> Update Software).

Note: If you do not want to continue in the software update, you have to switch off and on the fixture to escape from the updating mode.

We recommend to cancel all running programs on your computer before starting the software update.

5. Double-click the software uploader file (e.g. DSU_RobiniEsprite_18100828.exe) in the extracted files. The Software Uploader program will start to run.

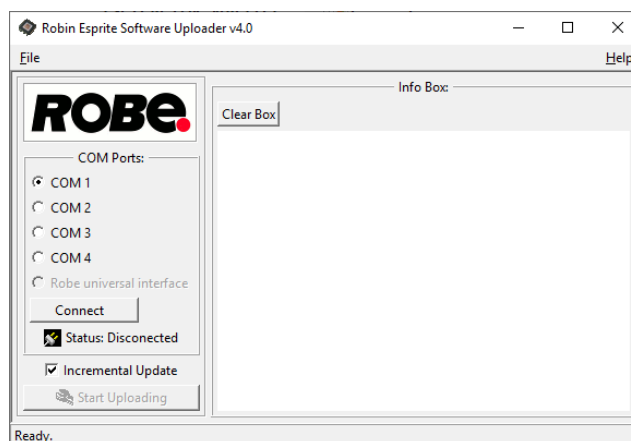

6. Select correct "COM " number if you use a Flash cable RS232/DMX or select "Robe Universal Interface " if you use the Robe Universal Interface/Robe Universal Interface WTX and then click on the "Connect" button.

7. If the connection is OK, click the "Start Uploading" button to start software uploading. It will take several minutes to perform software update.

If the option "Incremental Update" is not checked, all processors will be updated (including processors with the same software version).

If you wish to update only processors with new version of software, check the "Incremental Update box".

Avoid interrupting the process. Update status is being displayed in the "Info Box" window.

When the update is finished, the line with the text “Fixture is successfully updated“ will appear in this window.

In case upload process is interrupted (e.g. power loss), the fixture stays in “Updating mode” and you will have to repeat the software update again.

Another way, how to update software in the fixtures (especially large installation of fixtures) is to use the ROBE Uploader. It is a software for automatized software update of Robe fixtures. It takes advantage of RDM support).

For more information please see <https://www.robe.cz/robe-uploader/>.

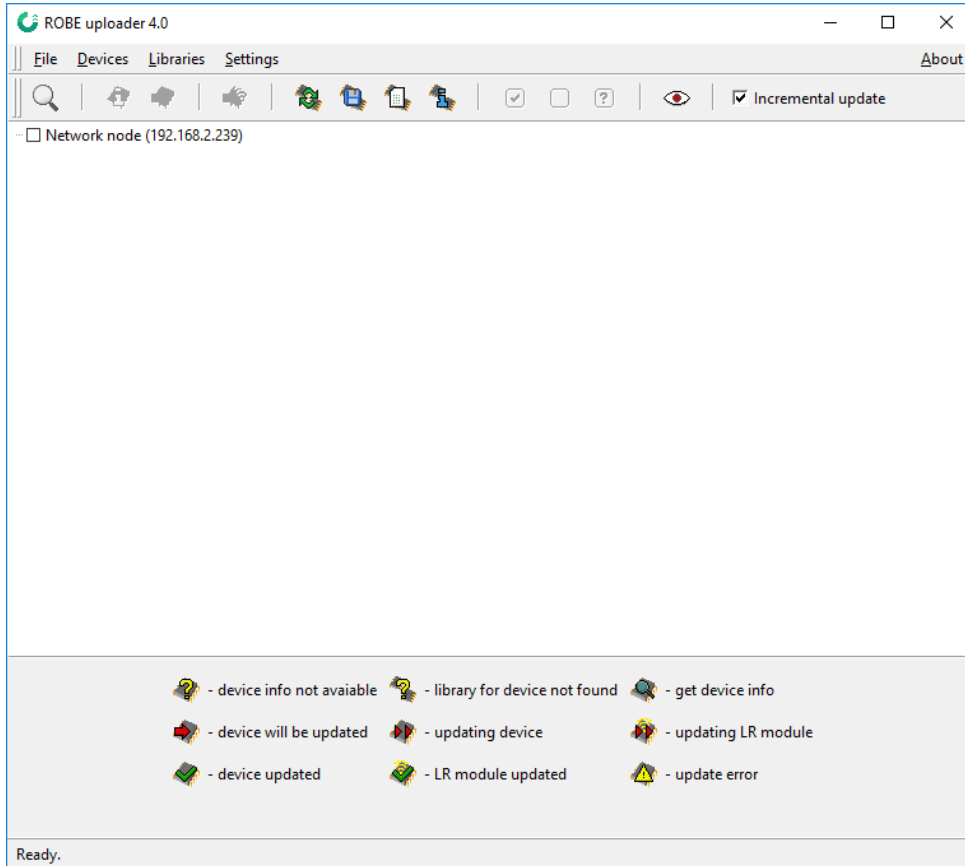

10. RDM

This fixture supports RDM operation. RDM (Remote Device Management) is a bi-directional communications protocol for use in DMX512 control systems, it is the new open standard for DMX512 device configuration and status monitoring.

The RDM protocol allows data packets to be inserted into a DMX512 data stream without adversely affecting existing non-RDM equipment. By using a special „Start Code,“ and by complying with the timing specifications for DMX512, the RDM protocol allows a console or dedicated RDM controller to send commands to and receive messages from specific moving lights.

RDM allows explicit commands to be sent to a device and responses to be received from it.

The list of commands for Robin iEsprite LTL is the following:

Parameter ID	Discovery command	SET command	GET command
DISC_UNIQUE_BRANCH	*		
DISC_MUTE	*		
DISC_UN_MUTE	*		
DEVICE_INFO			*
SUPPORTED_PARAMETERS			*
SOFTWARE_VERSION_LABEL			*
DMX_START_ADDRESS		*	*
IDENTIFY_DEVICE		*	*
DEVICE_MODEL_DESCRIPTION			*
MANUFACTURER_LABEL			*
DEVICE_LABEL		*	*
SENSOR_DEFINITION			*
SENSOR_VALUE			*
DISPLAY_INVERT		*	*
DISPLAY_LEVEL		*	*
PAN_INVERT		*	*
TILT_INVERT		*	*
DEVICE_RESET		*	
DMX_PERSONALITY		*	*
DMX_PERSONALITY_DESCRIPTION			*
STATUS_MESSAGES			*
STATUS_ID_DESCRIPTION			*

RDM model ID for the Robin iEsprite LTL is 0x0152.

If you need to set RDMnet scope, use the ROBE Ethernet Acces Portal (REAP) and menu Personality-->-->Ethernet Settings.

The screenshot shows the 'Ethernet settings' window with the following configuration:

- Ethernet mode:** disable ArtNet gMA1 gMA2 sACN
- Ethernet to DMX:** off on
- ArtNet universe:** 0
- MANet I/II universe:** 1
- MANet session ID:** 1
- sACN universe:** 1
- RDMnet scope:** default (highlighted with a red box)

A 'Save' button is located at the bottom right of the settings window.

11. Error and information messages

Error in the fixture is signalled by the yellow warning icon at the bottom line of the screen:



Touch the warning icon or press the [ESCAPE] button to display error messages.

List of error and information messages:

Pan Error 1

Mechanical end of the pan track was not detected.

Pan Error 2

Pan sensor error.

Pan Error 3

Pan feedback error.

Tilt Error 1

Mechanical end of the tilt track was not detected.

Tilt Error 2

Tilt sensor error.

Tilt Error 3

Tilt feedback error.

Colour Wheel 1 Error 1

Magnetic/optic sensor was not detected.

Colour Wheel 1 Error 2

Magnetic/optic sensor permanently detects colour wheel 1.

Colour Wheel 2 Error 1

Magnetic/optic sensor was not detected.

Colour Wheel 2 Error 2

Magnetic/optic sensor permanently detects colour wheel 2.

Prism Rot. Error 1

Magnetic/optic sensor was not detected at prisma wheel 1.

Prism Rot. Error 2

Magnetic/optic sensor permanently detects prism wheel 1.

Prism Error 1

Impact to the mechanical end of the prism wheel 1 track (prism wheel 2 track) was not detected.

Prism Error 4

Incorrect detection of a prism wheel 1 track (prism wheel 2 track). Impact to a mechanical obstruction was detected within running of the prism 1 (prism 2).

Iris Error 1

Impact to the mechanical end of the iris track was not detected.

Iris Error 4

Incorrect detection of a iris track. Impact to a mechanical obstruction was detected within running of the iris.

Frost Error 1

Impact to the mechanical end of the frost 1 track (frost 2 track) was not detected.

Frost Error 4

Incorrect detection of a frost 1 track (frost 2 track). Impact to a mechanical obstruction was detected within running of the frost.

Zoom Error 1

Impact to the mechanical end of the zoom track was not detected.

Zoom Error 4

Incorrect detection of a zoom track. Impact to a mechanical obstruction was detected within running of the zoom.

Focus 1 Error 1

Impact to the mechanical end of the focus module track was not detected.

Focus Error 4

Incorrect detection of a focus track. Impact to a mechanical obstruction was detected within running of the focus module.

Gobo Carousel Error 1

Magnetic/optic sensor was not detected.

Gobo Carousel Error 2

Magnetic/optic sensor permanently detects gobo carousel.

Gobo Rotation Error 1

Magnetic/optic sensor was not detected on the rotating gobo on the gobo carousel.

Gobo Rotation Error 2

Magnetic/optic sensor permanently detects rotating gobo on the gobo carousel.

Static Gobo Error 1

Magnetic/optic sensor was not detected.

Static Gobo Error 2

Magnetic/optic sensor permanently detects static gobo wheel.

Effect Wheel Error 1

Impact to the mechanical end of the effect wheel track was not detected.

Effect Wheel Error 4

Incorrect detection of an effect wheel track. Impact to a mechanical obstruction was detected within running of the effect wheel.

Fr. Shutters Rot. Error 1

Impact to the mechanical end of the framing shutters wheel was not detected.

Fr. Shutters Rot. Error 2

Incorrect detection of the framing shutters wheel. Impact to a mechanical obstruction was detected within running of the framing shutters wheel.

Fr. Shutter 1 Error 1

Impact to the mechanical end of the framing shutter 1 was not detected.

Fr. Shutter 1 Error 4

Incorrect detection of the framing shutter 1. Impact to a mechanical obstruction was detected within running of the framing shutter 1.

Fr. Shutter 2 Error 1

Impact to the mechanical end of the framing shutter 2 was not detected.

Fr. Shutter 2 Error 4

Incorrect detection of the framing shutter 2. Impact to a mechanical obstruction was detected within running of the framing shutter 2.

Fr. Shutter 3 Error 1

Impact to the mechanical end of the framing shutter 3 was not detected.

Fr. Shutter 3 Error 4

Incorrect detection of the framing shutter 3. Impact to a mechanical obstruction was detected within running of the framing shutter 3.

Fr. Shutter 4 Error 1

Impact to the mechanical end of the framing shutter 4 was not detected.

Fr. Shutter 4 Error 4

Incorrect detection of the framing shutter 4. Impact to a mechanical obstruction was detected within running of the framing shutter 4.

EEprom Error

Hardware error of the EEprom.

Recharge The battery

The battery on the display board needs to be charged. Let the fixture on for cca 6 hrs.

Battery Faulty. Replace it.

The battery on the display board is exhausted and should be replaced immediately.

Pan/Tilt EMS Cal. Error

The EMS system is not calibrated.

Pan/Tilt EMS Error

Control electronics cannot communicate with the EMS system.

Internal Error 1

Communication error between PCBs (error or noise was detected on communication wires)

Internal Error 2

Communication error (some PCB has failed or is disconnected (this PCB will show as N/A in menu --> Information --> Software versions) or error/interference was detected on communication wires)

Overheated

The LED engine is overheated and light output is closed.

White 1 Short Error (White 2 Short Error/ White 3 Short Error/ White 4 Short Error)

Some white LEDs in the light source have short circuit or are disconnected.

White 5 Short Error (White 6 Short Error/ White 7 Short Error/ White 8 Short Error)

Some white LEDs in the light source have short circuit or are disconnected.

Temperature Sensor Error

Some of temperature sensor in fixture head (LEDs or driver) is faulty.

Too Much Humidity in Device

To remove the message, reset the bar chart Max.Wet in the menu RAINS Status (tab Information) and check the silica gel desiccants in the fixture arm.

Valve Seal Error

The valve in fixture arm or coil in the valve is defective or there is a connection problem between the valve and head, check cable connector at valve.

Base Fan Bad

One or both fans in the fixture base are disconnected from their control PCB or are faulty and has to be replaced.

Positions of cooling fans, their control PCBs and control processors:

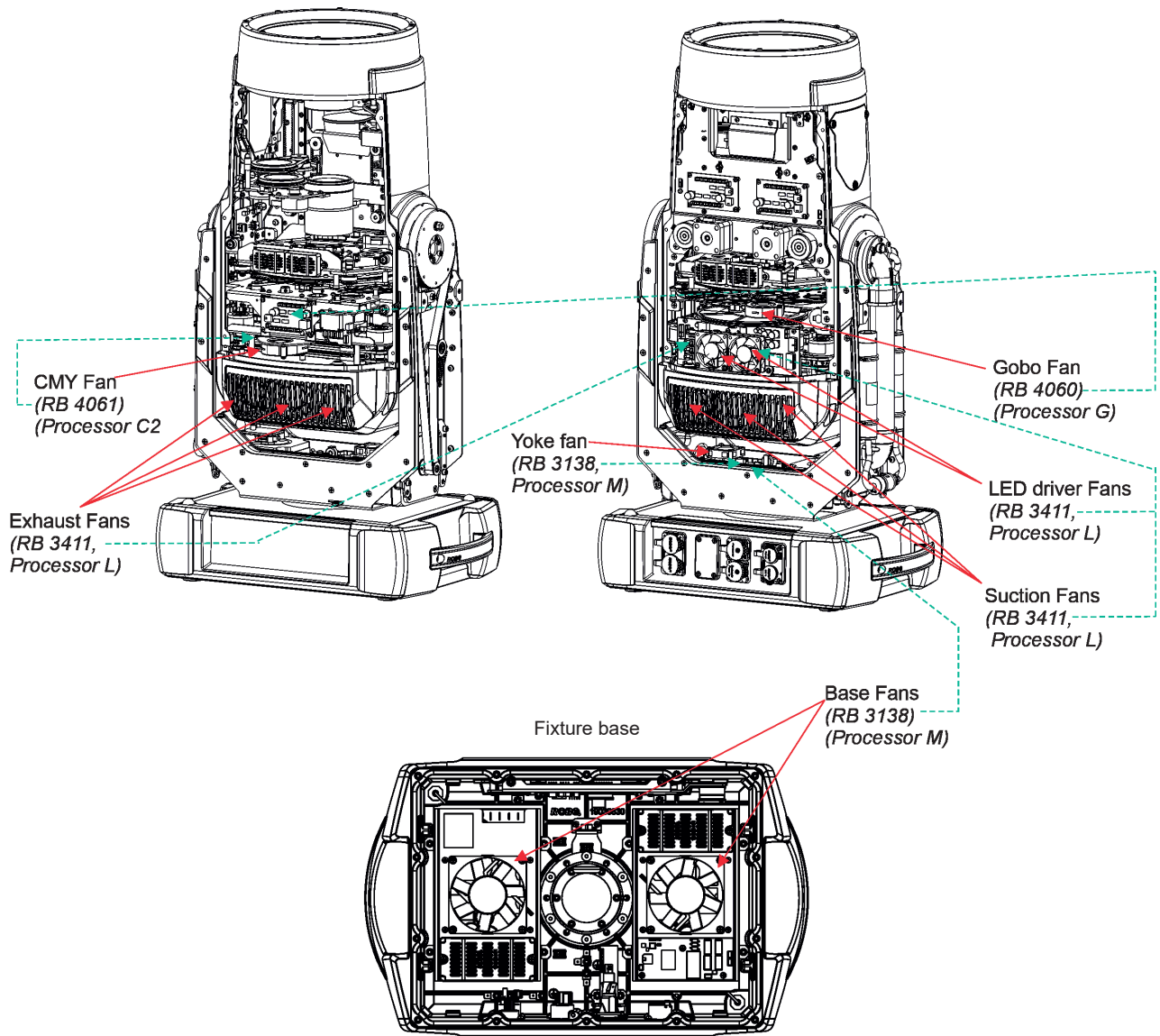

12. NFC

The fixture supports NFC (Near-Field Communication). Using the mobile phone application ROBE COM you can read and set the Robin iEsprite LTL parameters (DMX address, IP address...etc.), get information about temperatures, operation hours, RDM identification etc.

The NFC point is situated on the front panel of fixture's base.



Download and install the ROBE COM from Google Play (for Android 7.1 and higher) or App Store (for iOS 15.0 and higher) to your mobile phone. Your mobile phone has to support NFC.

After installing the ROBE COM, run the application by touching the icon .

Hold the mobile phone on the side of the fixture base near to NFC point, if NFC connection is OK, touch the item "SETUP DEVICES", then "iEsprite LTL" and the following menu items will appear:

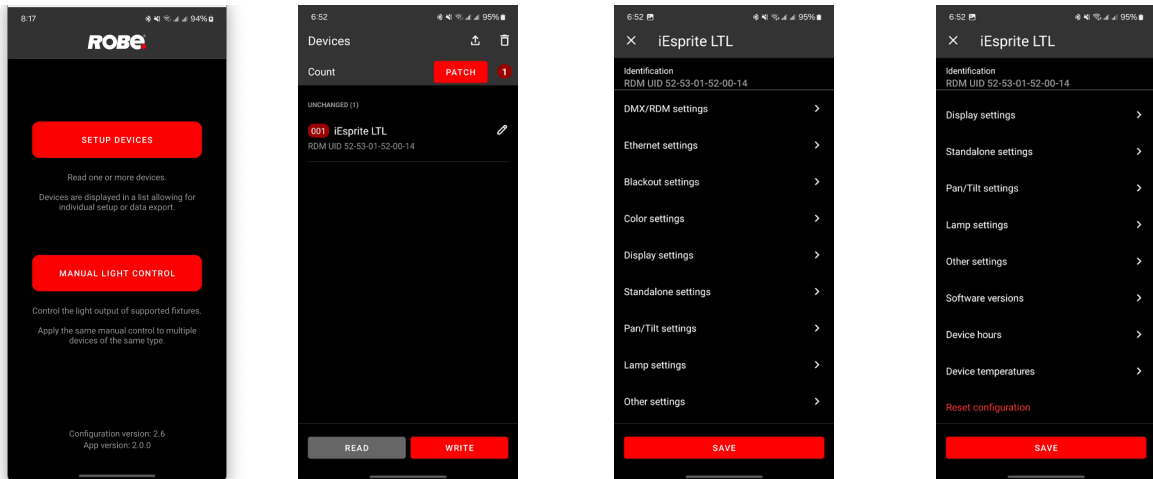

Note. Displayed menu is universal, some menu item can be disabled for specific type of the fixture. The fixture can be disconnected from mains during loading and saving data to the fixture, but some changes will be active after switching the fixture on.

Changes made in selected menu item can be saved by touching the item "SAVE". The item "WRITE" sends all changes to the fixture.

Menu item "MANUAL LIGHT CONTROL" currently serves for Anolis fixtures (Lyrae S, Lyrae M) only.

13. Cleaning

DANGER !
Always disconnect the fixture from mains before starting any cleaning work.

Regular cleaning will not only ensure the maximum light output, but will also allow the fixture to function reliably throughout its life.

The frequency of cleaning depends on the environment in which the fixture operates: damp, smoky or particularly dirty environments can cause greater accumulation of dirt on the fixture housing.

The front glass cover of the head will require cleaning on a monthly basis. A soft lint-free cloth dampened with a solution of water and a mild detergent is recommended, under no circumstances should alcohol, solvents or abrasives be used!

Stains caused by hard water (water that has high mineral content) can be effectively removed by means of non - abrasive descaler (e.g. EverStar descaler).

14. Maintenance

DANGER !

***Do not do maintenance in a damp environment (e.g. rain, snowfall)!
Always disconnect the fixture from mains before starting any maintenance work.***

In order to ensure the fixture remains in good condition and does not fail prematurely, we recommend regular maintenance.

The following points have to be considered during fixture inspection:

- All outside covers and screws should be checked for damages, scratches or corrosion.
- All connectors and its rubber caps should be checked for damages or sediments.
- All screws and fasteners has to be securely tightened. Check for any deformation on the housing and rigging points. Damaged rigging points or unsecured rigging could cause the fixture to fall and seriously injure people.
- Electric power supply cable must not show any damage or material fatigue.
- Fans and heatsink should be checked for sediments or dirt/debris accumulation.

User can do the following operations:

- Gobo replacement
- Frost replacement
- LEDs module replacement
- Silica gel desiccants replacement
- Main fuse replacement
- Battery replacement
- Lubrication of internal parts of the fixture

Another maintenance and service operations should be carried out by trained technician only. If you need any spare parts, please order genuine parts from your local Robe distributor.

In case of problem with smooth running of CMY colour mixing system, lubricate sliding bars of CMY flags. As lubricant we recommend ÄRONIX silicone oil 500 cSt - it is a medium viscosity lubricant, release agent, high temperature oil.

Fixture metal covers are made of material resistant to corrosion, potential damages of covers (like scratches, abrasions) are only appearance defects and will not cause corrosion of covers.

To repair small damages of fixture metal covers (e.g. scratches), you can use a paint intended for non-rusting metal surfaces (like aluminium, copper...). The paint can be applied to surface by means of a small brush or by spraying.

Use the paint with the same colour and sheen as has your cover. The paint can perform as undercoat or top-coat, it doesn't matter.

Do not remove fixture covers in smoky or particularly dirty environment (e.g. with fog machines).

IMPORTANT The fixture head should be uncovered as short time as possible (about 1-2 hours depending on air humidity) otherwise silica gel in small boxes in the fixture head may become damp.

If you have removed head cover and you need to interrupt your work for longer time (hours, days), we recommend to place the head cover on the head and fasten it provisionally by means of two screws, next possibility is unscrewing small boxes with silica gel from the head and put it to a sealed container with limited access of air (e.g. sealed plastic bag).

The same rule should be kept for silica gel desiccants in the fixture base in case of service intervention (at removing bottom base cover).

Replacing the fuse.

Before replacing the fuse, disconnect the fixture from mains.

1. Remove the cover (1) of the battery and fuse compartment by unscrewing four screws (2) with sealing rings.
2. Using a flat-blade screwdriver, unscrew (anti-clockwise) the fuse holder from the rear panel of the base.
3. Remove the blown fuse from the fuse holder.
4. Place a good fuse (only the same type and rating) into the fuse holder and screw the fuse holder back.
5. Place the cover (1) with gasket (3) back on the rear panel of the fixture and fasten it by means of the four screws (2) with sealing rings. Tighten screws crosswise in two steps:
Step 1 - use tightening torque 0.5Nm (pre-tightening)
Step 2 - use tightening torque 2.5Nm (final tightening)

Replacing the battery.

Before replacing the battery, disconnect the fixture from mains.

1. Remove the cover (1) of the battery and fuse compartment by unscrewing four screws (2) with sealing rings.
2. Loosen (anti-clockwise) the battery holder cap.
3. Remove the exhausted battery from the battery holder.
4. Place a new battery (only the same type) into the battery holder (Negative (-) inside, Plus (+) outside).
5. Place and tighten the battery holder cap back.
6. Place the cover (1) with gasket (3) back on the rear panel of the fixture and fasten it by means of the four screws (2) with sealing rings. Tighten screws crosswise in two steps:
Step 1 - use tightening torque 0.5Nm (pre-tightening)
Step 2 - use tightening torque 2.5Nm (final tightening)

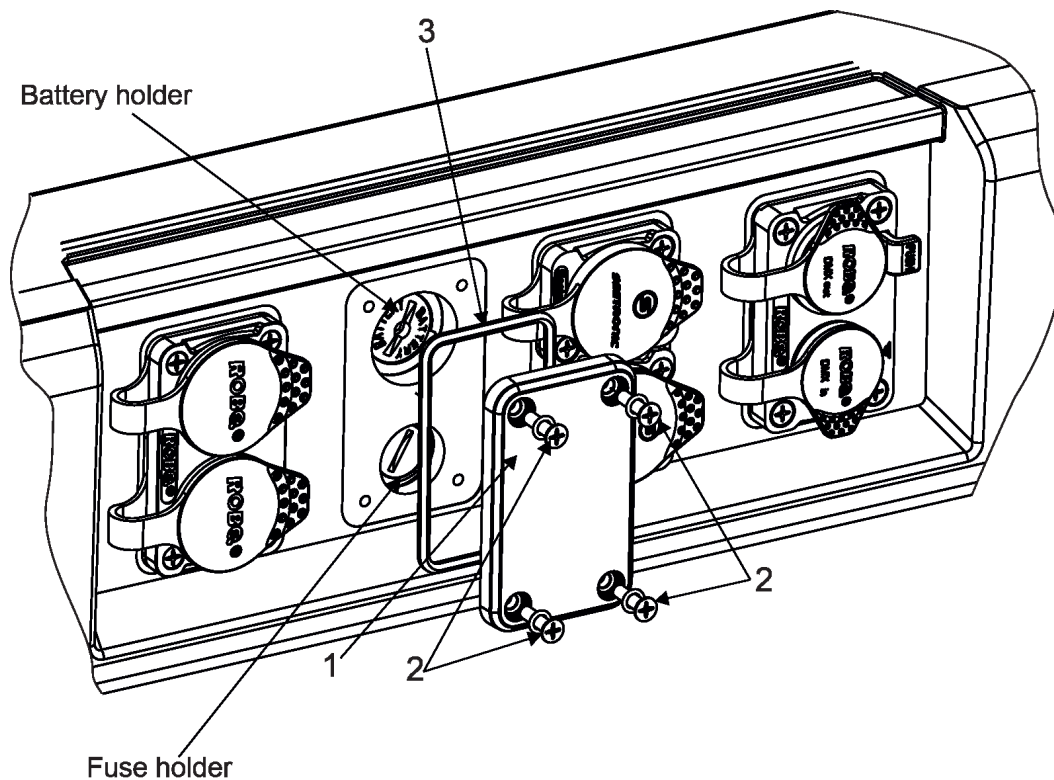

Changing pan/tilt motors or pan/tilt driver.

In case of change of pan motor or tilt motor or pan/tilt control PCB (RB 3138 in the fixture yoke), you have to run the procedure Calibrate Pan/Tilt Reset in the tab "Service" (tab Service--> Calibrations --> Calibrate Pan/Tilt Reset).

14.1 Fixture watertight covers and torques of covers screws

Keep values of torques as stated on pictures below otherwise leakage issues can occur!

Run the procedure Pressure Test (Service --> Pressure Test) after replacing any watertight cover!

Bottom base cover

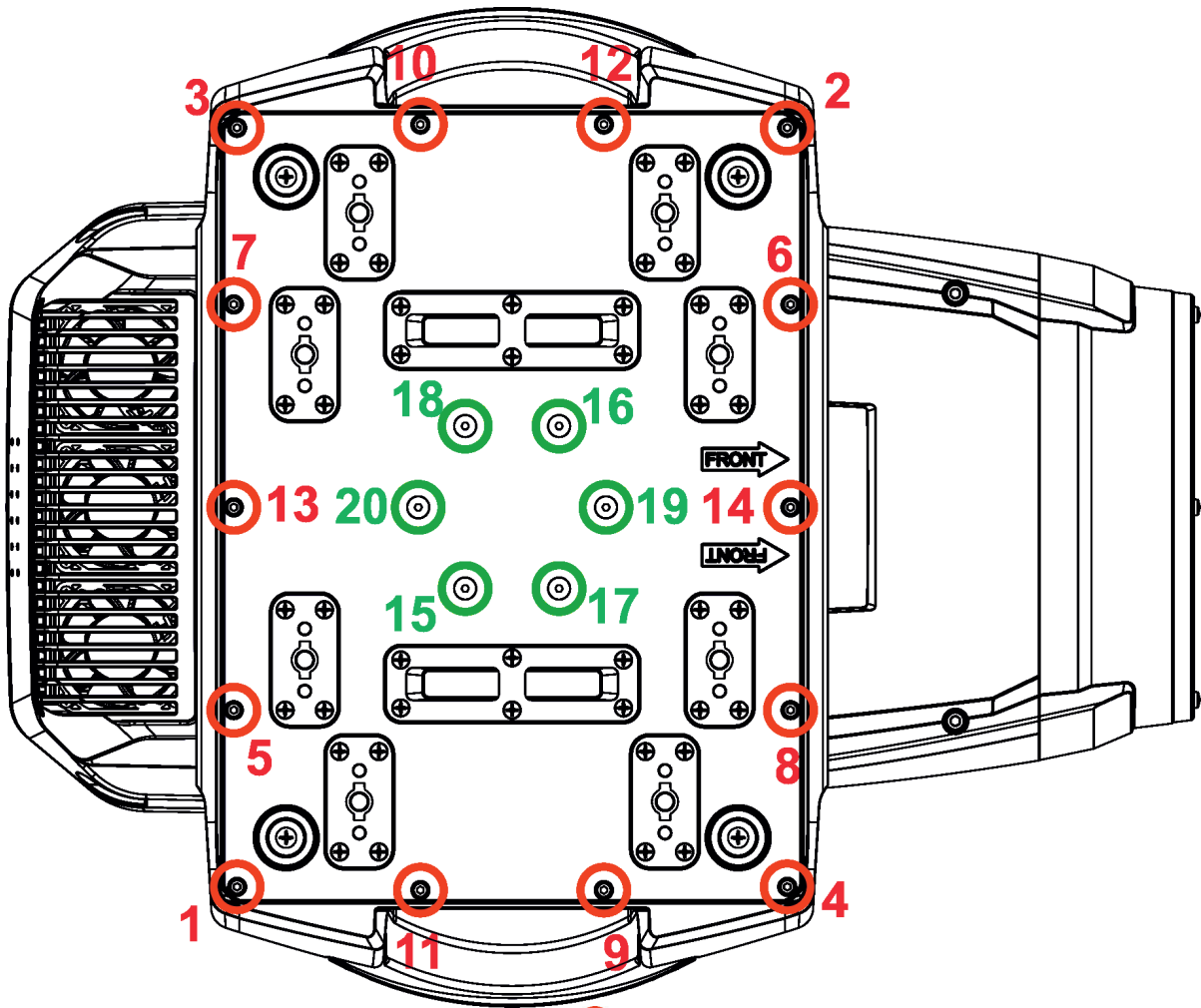

Screws must be tightened in the order 1-->14
15-->20.

- 14 x hex socket head screw M4x14 with spring washer
Tightening torque*: 2.5 Nm
- 6 x flat head screw M5x18 with rubber ring
Tightening torque*: 2.5 Nm

* Tighten all screws in two steps:

Step 1 - use tightening torque 0.5Nm (pre-tightening)

Step 2- use tightening torque 2.5Nm (final tightening)

Carefully check the gasket for signs of deformities or damages and if it is correctly placed before screwing the bottom base cover back. The gasket is part of the base.

Do not forget to connect grounding wire between chassis and base cover.

Head covers (on both sides of the head)

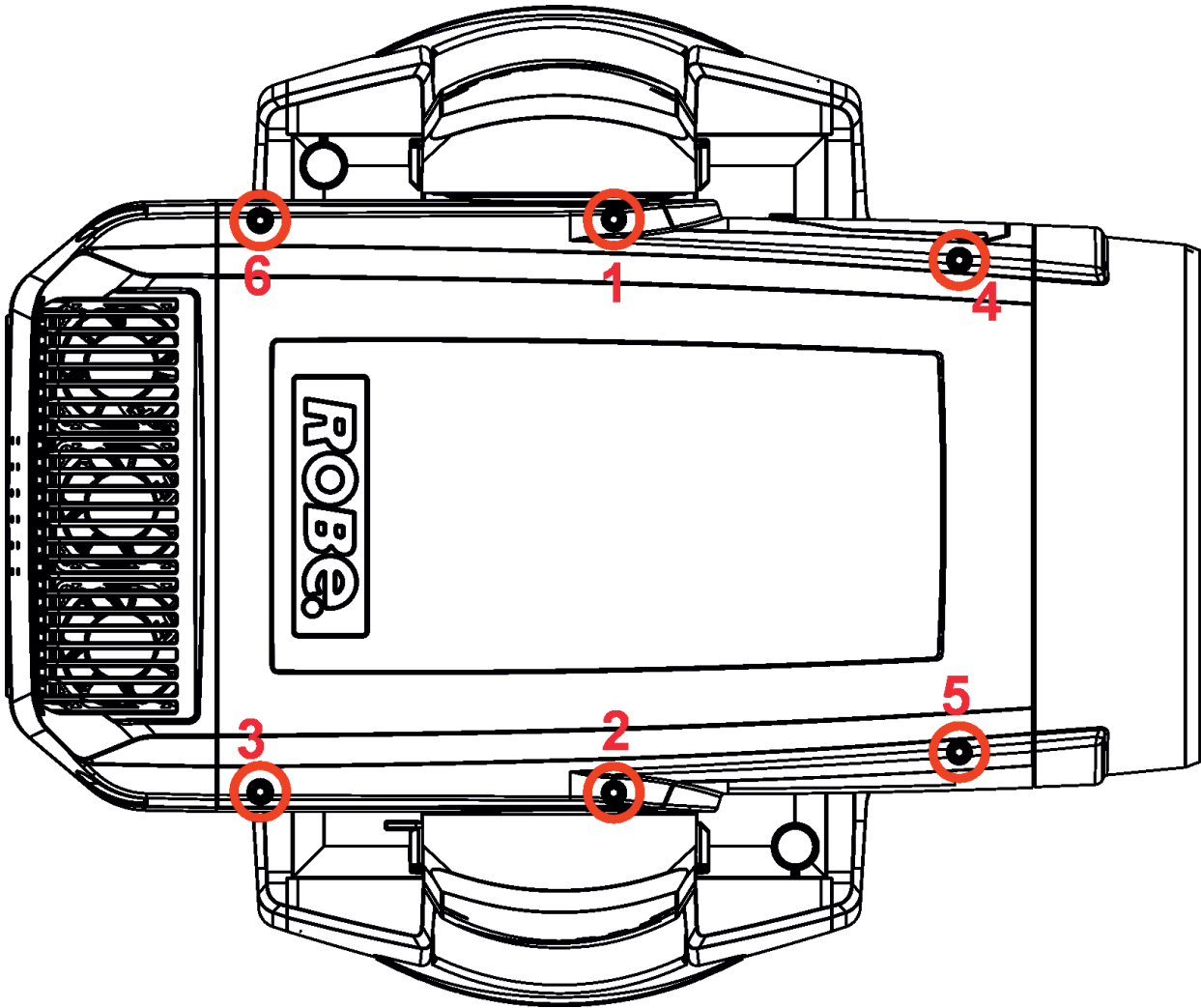

Screws must be tightened
in the order 1-->6

6 x hex socket head screw M5x16
Tightening torque*: 2.5 Nm

* Tighten all screws in two steps:
Step 1 - use tightening torque 0.5Nm (pre-tightening)
Step 2- use tightening torque 2.5Nm (final tightening)

Carefully check the gasket for signs of deformities or damages and if it is correctly placed before screwing head covers back. The gasket is part of the head cover.
Do not forget to connect grounding wire between chassis and head cover.

Yoke cover

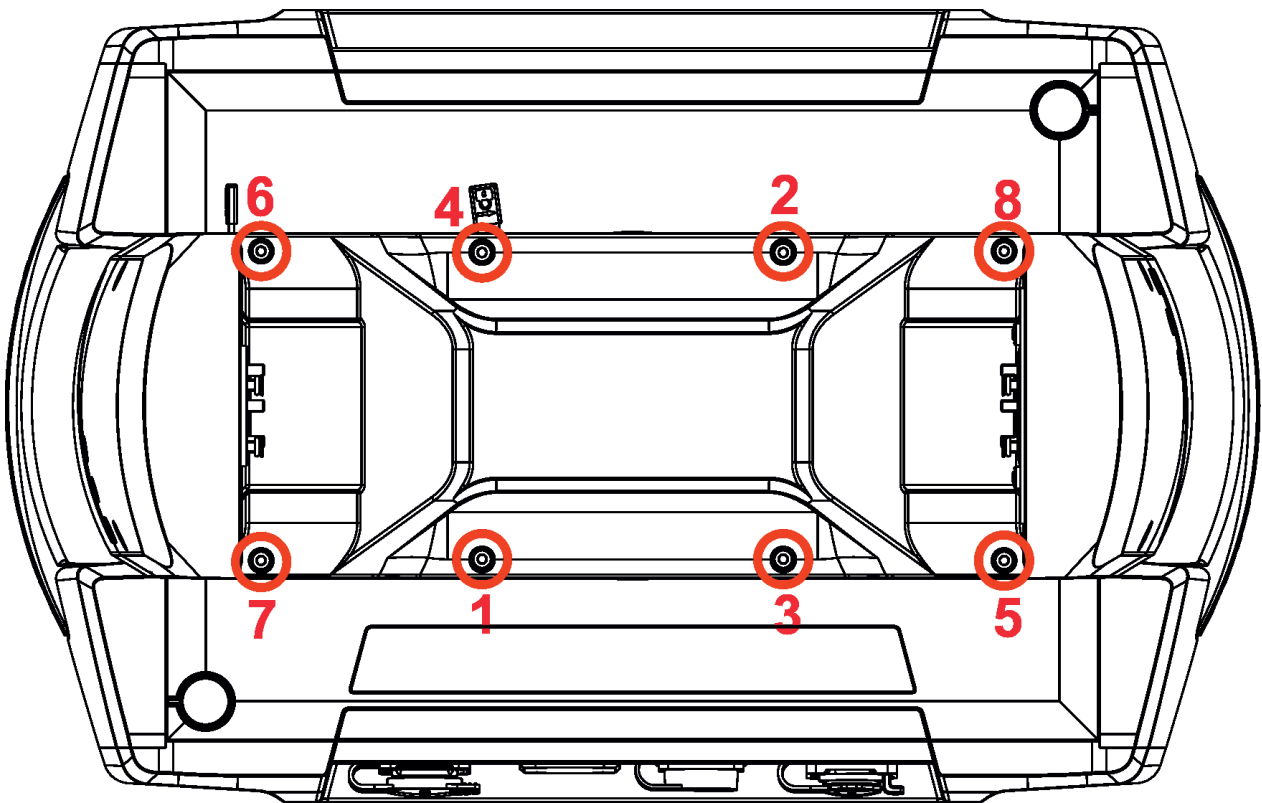

Screws must be tightened
in the order 1-->8

8 x hex socket head screw M4x8
Tightening torque*: 2.5 Nm

* Tighten all screws in two steps:

Step 1 - use tightening torque 0.5Nm (pre-tightening)

Step 2- use tightening torque 2.5Nm (final tightening)

Carefully check the gasket for signs of deformities or damages and if it is correctly placed before screwing the yoke cover back. The gasket is part of the yoke cover.

Do not forget to connect grounding wire between chassis and yoke cover.

14.2 Torques of Pan/Tilt motors screws

Tilt motor

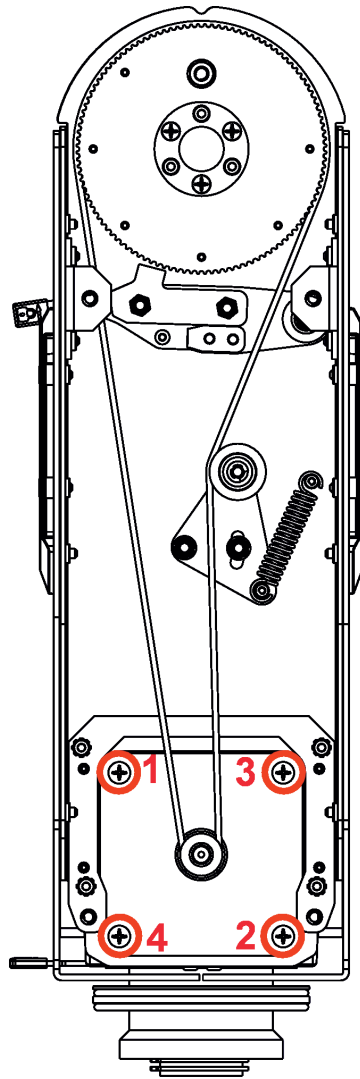

Note: In case of change of pan motor or tilt motor or pan/tilt control PCB (RB 3138 in the fixture yoke), you have to run the procedure Calibrate Pan/Tilt Reset in the tab "Service" (tab Service--> Calibrations --> Calibrate Pan/Tilt Reset)

4 x flat head screw M5x16 (stainless)
with sealing ring 5x1.5
Tightening torque*: 2.5 Nm

Screws must be tightened in the order 1-->4,
Use LOXEAL 55.03 (nut locking threadsealing)
on each screw

* Tighten all screws in two steps:
Step 1 - use tightening torque 0.5Nm
(pre-tightening)
Step 2- use tightening torque 2.5Nm
(final tightening)

Pan motor

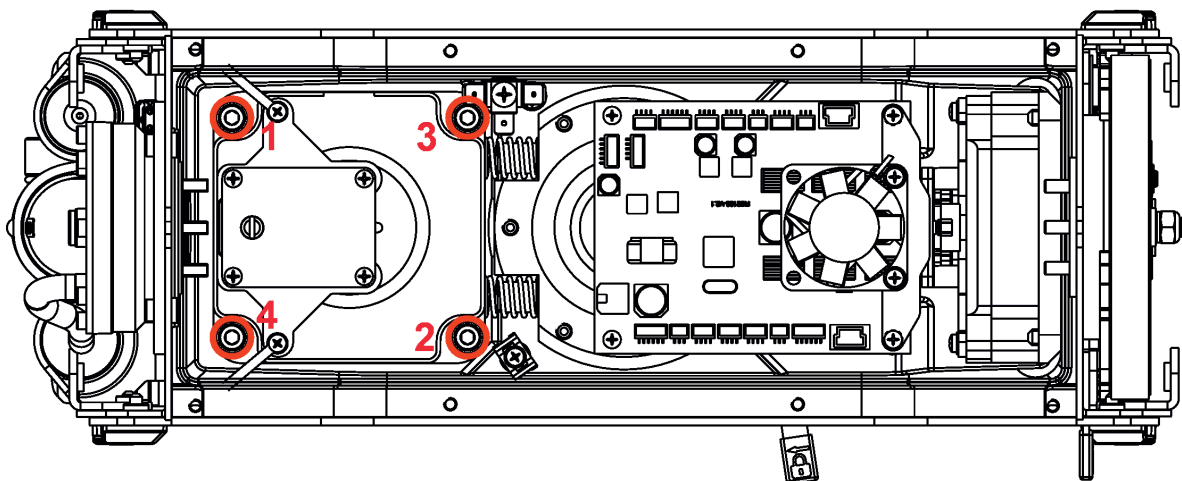

4 x hex socket head screw M5x20 (stainless) with
washer
Tightening torque*: 2.5 Nm

Screws must be tightened in the order 1-->4.
Use LOXEAL 55.03 (nut locking threadsealing)
on each screw

* Tighten all screws in two steps:
Step 1 - use tightening torque 0.5Nm (pre-tightening)
Step 2- use tightening torque 2.5Nm (final tightening)

14.3 Changing the LED light source

The Robin Forte allows you to change the LED light source and this way keep a high performance of the fixture.

***Unplug the fixture from mains before replacing LED light source!
Do not change LED light source in a damp environment (e.g. rain, snowfall)!***

To change the LED light source.

1. Disconnect the fixture from mains and allow it to cool about 60 minutes.
2. Lock the head in a horizontal position.
3. Remove the rear cover (1) of the fixture head by unscrewing two screws M5x20 (2) on each side of the cover.

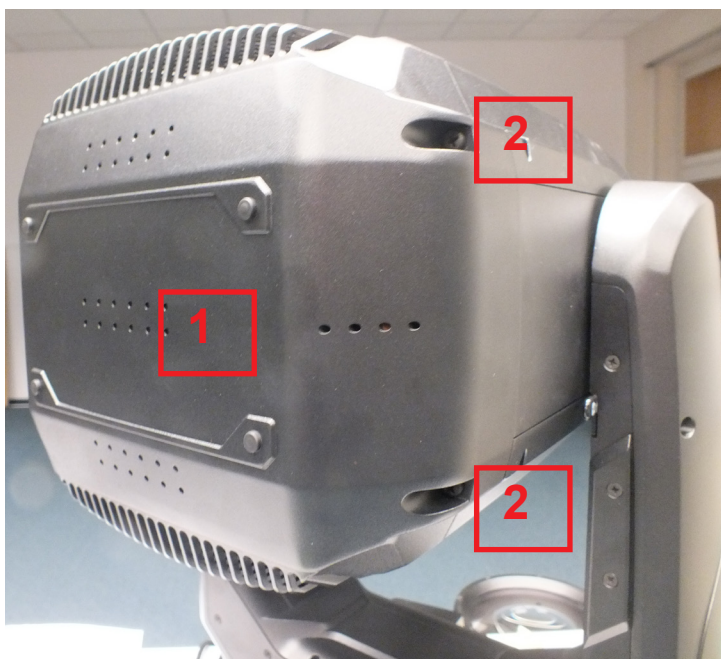

4. Unscrew the four screws M4x16 (4) with washers and rubber circles and four screws M4x14 (5) with washers and remove the LED light source (6) from the head. Be careful, the LED light source is heavy.

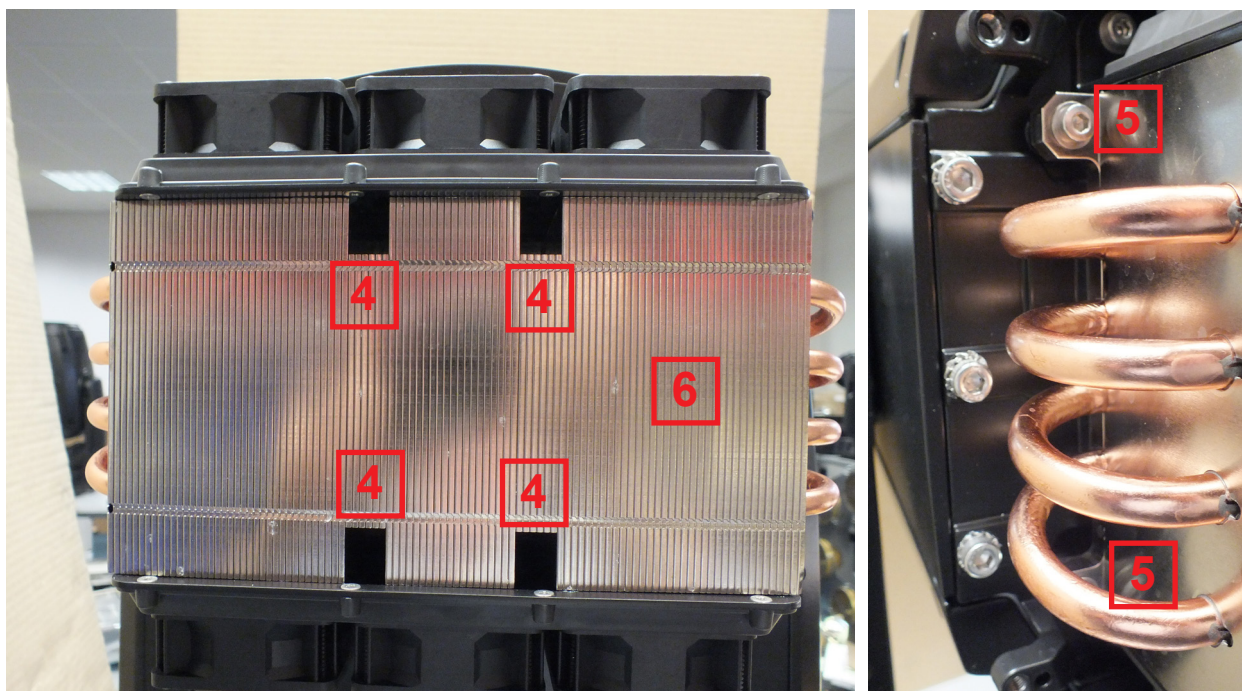

Fixture head without the LED light source.

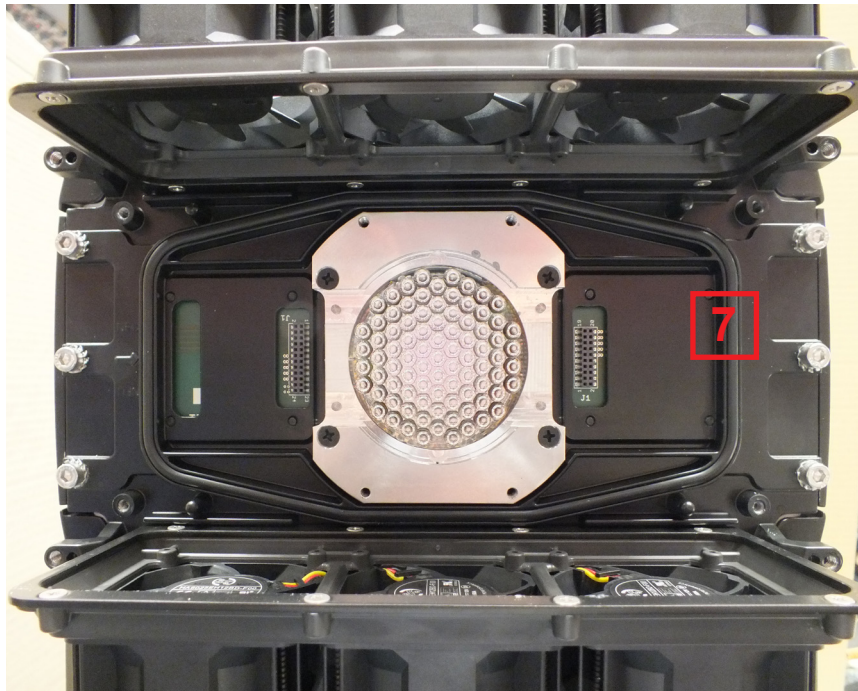

Important: Carefully check the gasket (7) for signs of deformities and if it is correctly placed in the chassis of the head before inserting the new LED light source.

The new LED light source includes PCB with LEDs and heat sink. Handle with care. Do not touch LEDs with bare hands.

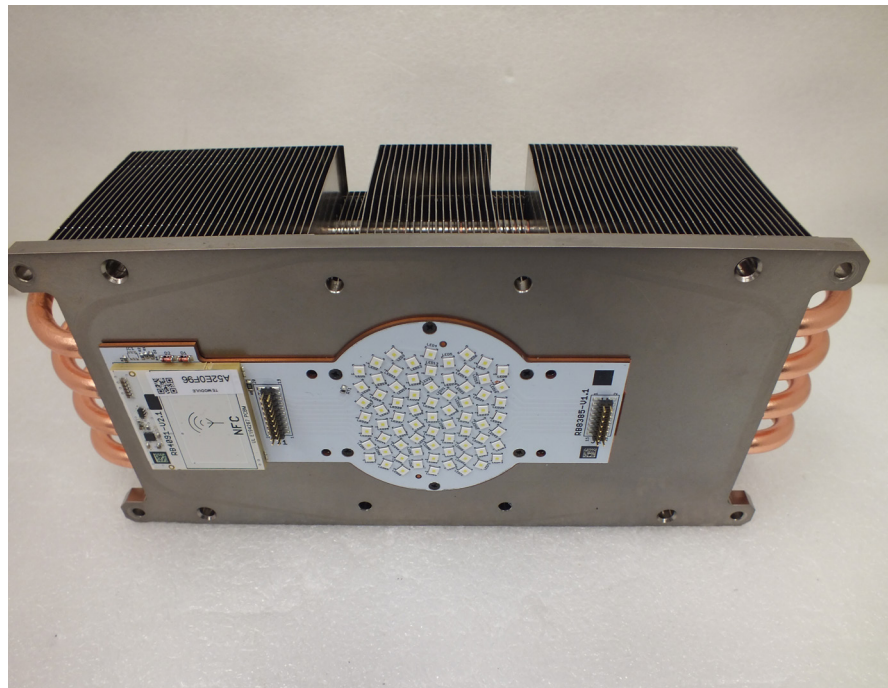

5. Carefully insert the new LED light source to the head. **Keep the correct orientation of the LED light source towards the head chassis as shown on the picture below. The NFC module on LEDs PCB has to be oriented towards the sign "NFC" on the fixture chassis.**

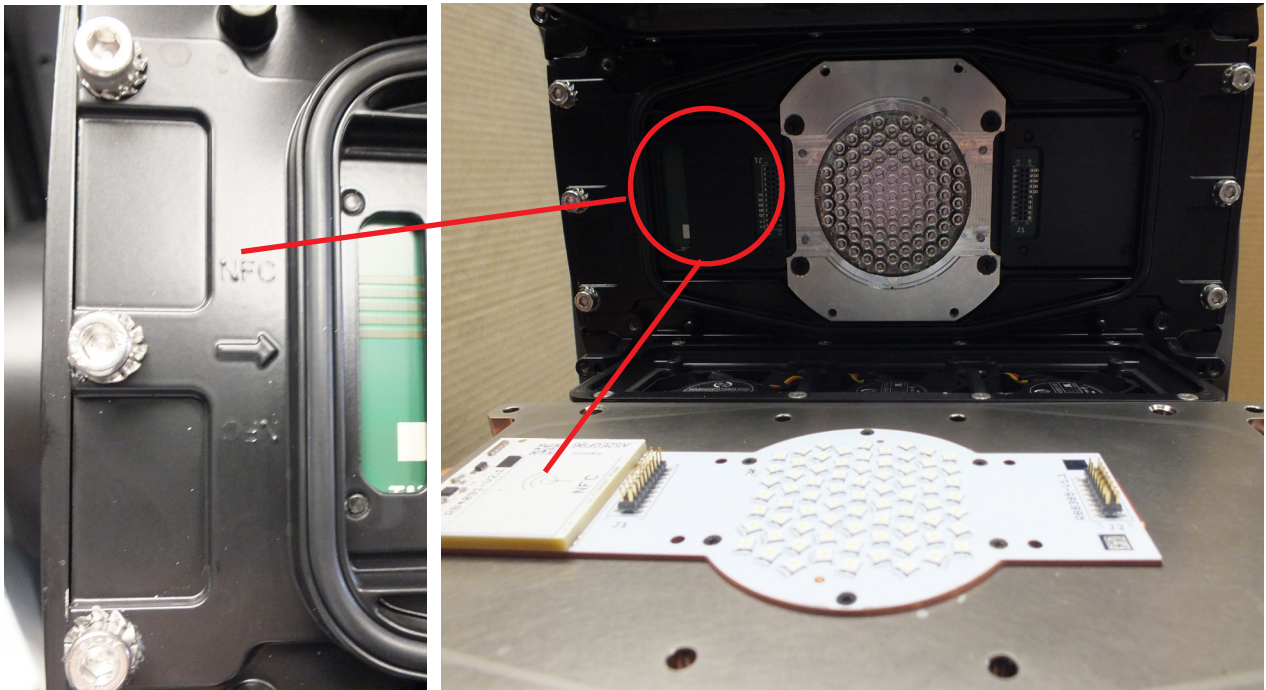

The four guide pins (8) secure correct position of the LED light source.

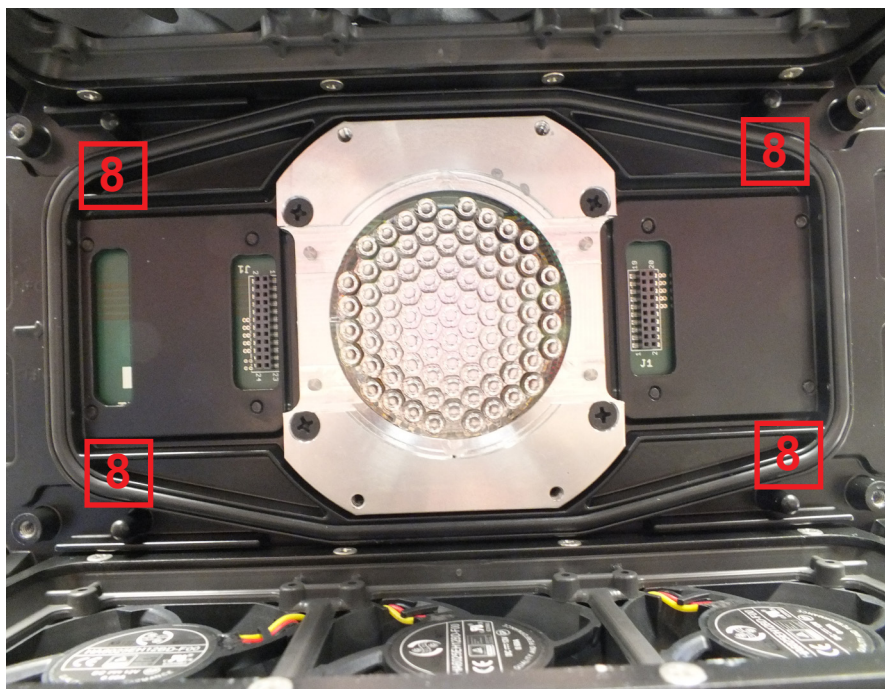

6. Tighten the four fastening screws M4 x14 (4) / with washers and rubber rings/ in the order 1-->4. Use tightening torque 2.5 Nm. Do the tightening of screws in two steps, in the first step use tightening torque 0.5 Nm and in the second step 2.5 Nm.

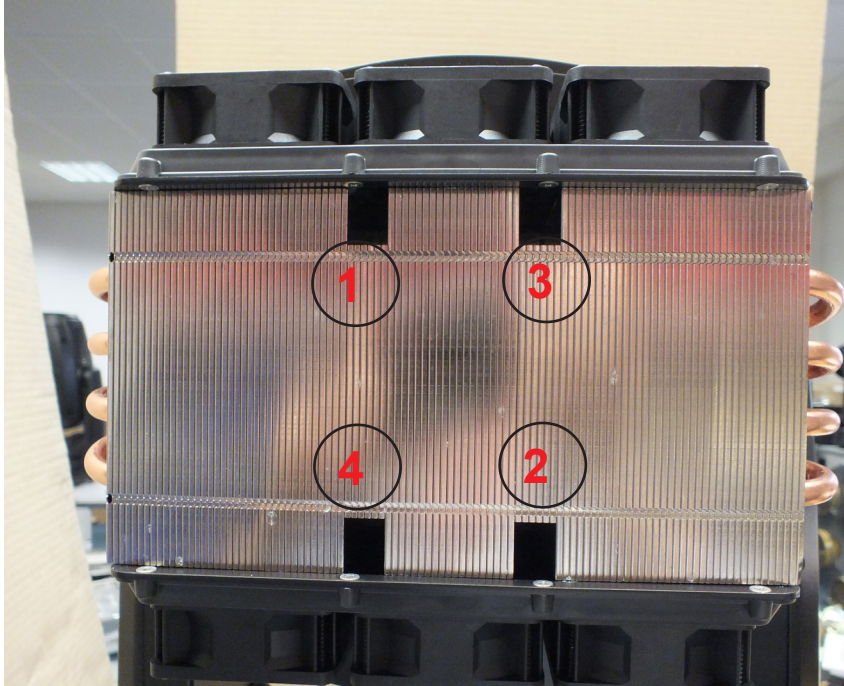

Tighten the four outside fastening screws M4x14 (5) with washers in the order 1-->4. Use tightening torque 2.5 Nm. Do the tightening of screws in two steps, in the first step use tightening torque 0.5 Nm and in the second step 2.5 Nm.

Note: Check that all screws are firmly tightened. Fastening of the LED light source has to be watertight.

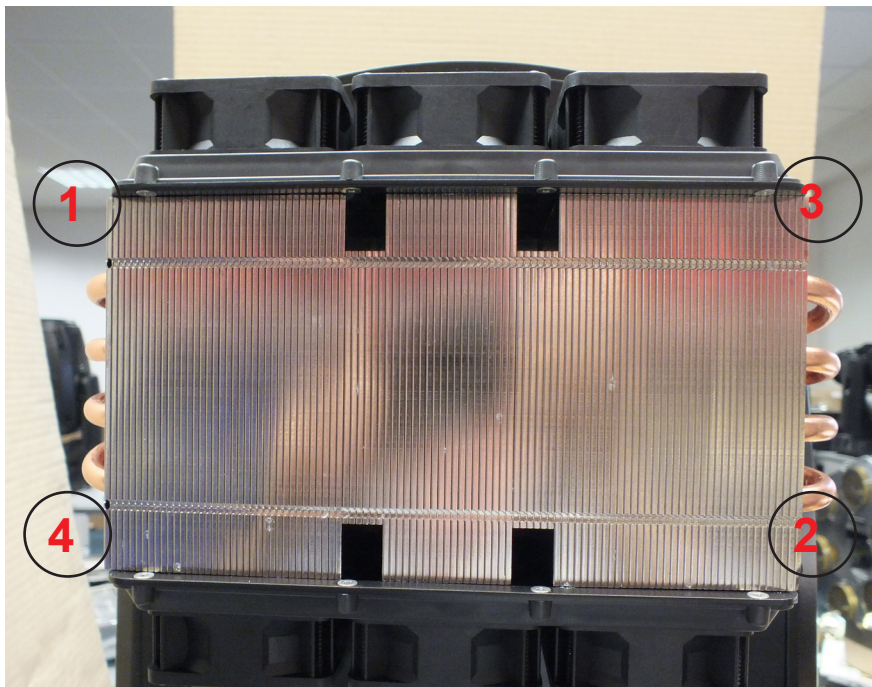

7. Screw the rear cover (1) of the fixture head by means of four screws M5x20 (2).

8. **After connecting the fixture to mains, run the procedure Pressure Test (Service -->Pressure Test).** If the pressure test is not OK, check tightening of the LED light source and run the pressure test again.

14.4 Checking and replacing the silica gel desiccants

The silica gel desiccants are used for humidity indication in the fixture. Dry silica gel has an orange colour, if it is saturated with water, its colour changes to dark grey. If most of silica gel changed colour to dark grey, it has to be replaced.

***Unplug the fixture from mains before checking/replacing silica gel desiccant!
Do not check/replace silica gel desiccant in a damp environment (e.g. rain, snowfall)!***

***Spare desiccants from factory are packaged in a protective foil. Take desiccants out of the protective foil immediately before replacing them in the fixture!
Silica gel may become damp if it is exposed to wet air for longer time.***

Silica gel is not under warranty!

Desiccants are placed in the fixture on the following places:

fixture head - 4 x small box with silica gel

fixture arm without tilt lock - 2 x tube with silica gel

fixture base - 2 x box with silica gel

Total weight of all silica gel fillings in the fixture is 207 g.

Fixture head

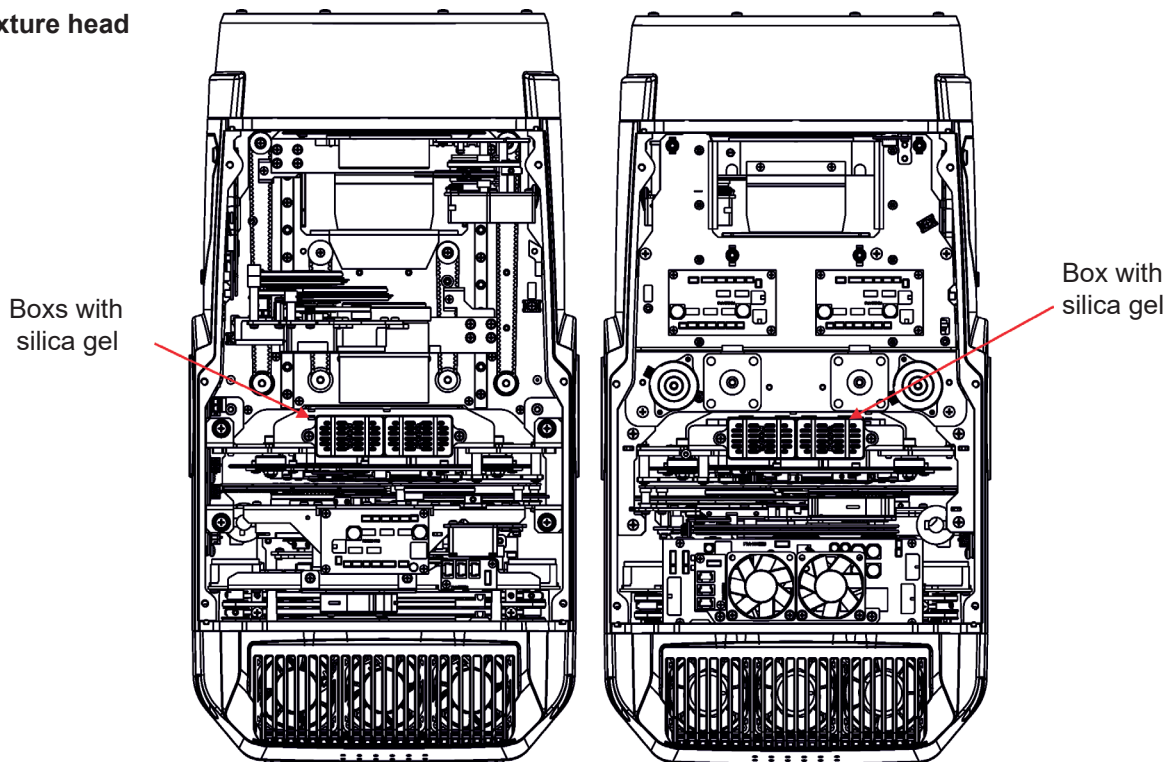

Fixture base

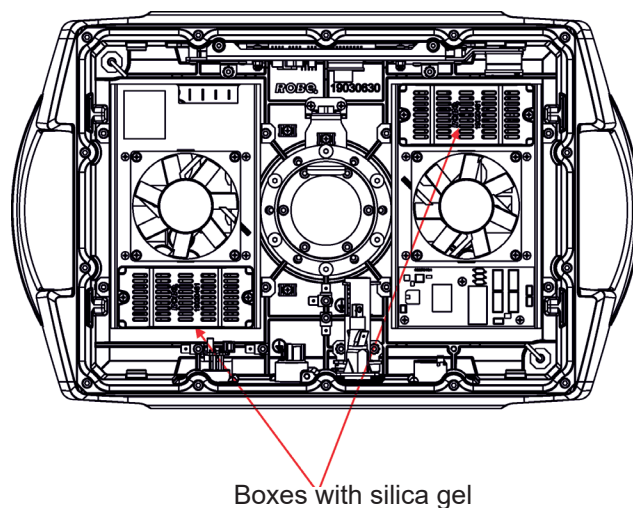

Each silica gel box is fastened in the fixture by means of two screws.

Example:

Dry silica gel

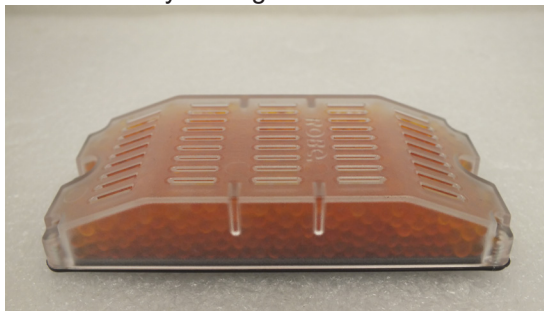

Silica gel saturated with water

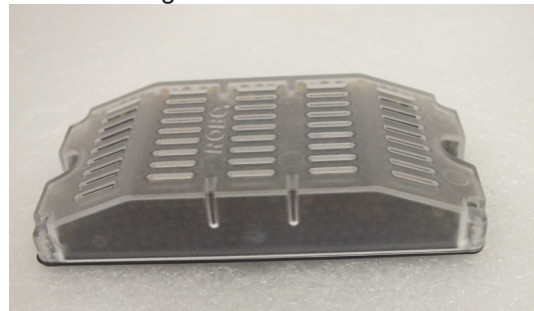

The silica gel desiccants in the fixture head should be checked (and alternatively replaced) at removing head covers, e.g. at gobos change.

The silica gel desiccants in the fixture base should be checked (and alternatively replaced) at removing bottom cover e.g. at service intervention.

After checking/replacing boxes with silica gel do not forget to connect grounding wire between chassis and base cover (head cover) at placing the covers back.

After checking/replacing boxes with silica gel, run the procedure Pressure Test (Service -->Pressure Test).

If the pressure test is not OK, check if all screws of head covers (base cover) are correctly tightened.

Fixture arm

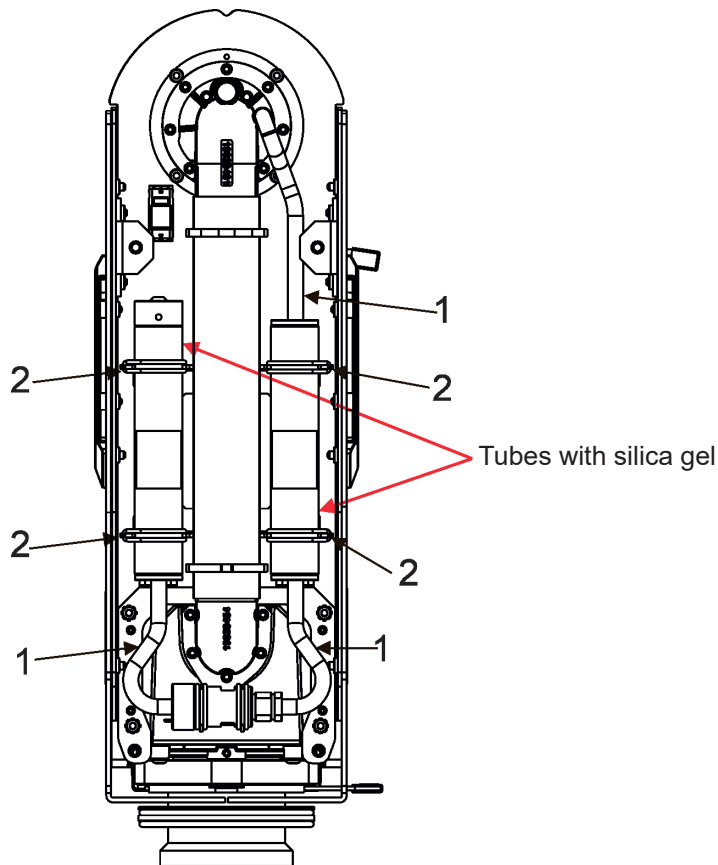

To change the tube with silica gel:

1. Disconnect the fixture from mains.
 2. Remove the arm cover.
 3. Disconnect the hosepipe(s) (1) from the tube with silica gel.
 4. Stick out the rubber rings (2) and remove the tube with silica gel.
 5. Insert the new tube with silica gel and secure it by means of the rubber rings (2).
 6. Connect the hosepipe(s) (1) to the tube with silica gel.
 7. Screw the arm cover back.
 8. **After connecting the fixture to mains, reset the MAX WET chart (tab Information-->RAINS Status) and run the procedure Pressure Test (tab Service -->Pressure Test).**
- If the pressure test failed, check if hose-pipes are correctly put on the tubes with silica gel.

Example of dry silica gel and silica gel saturated with water:

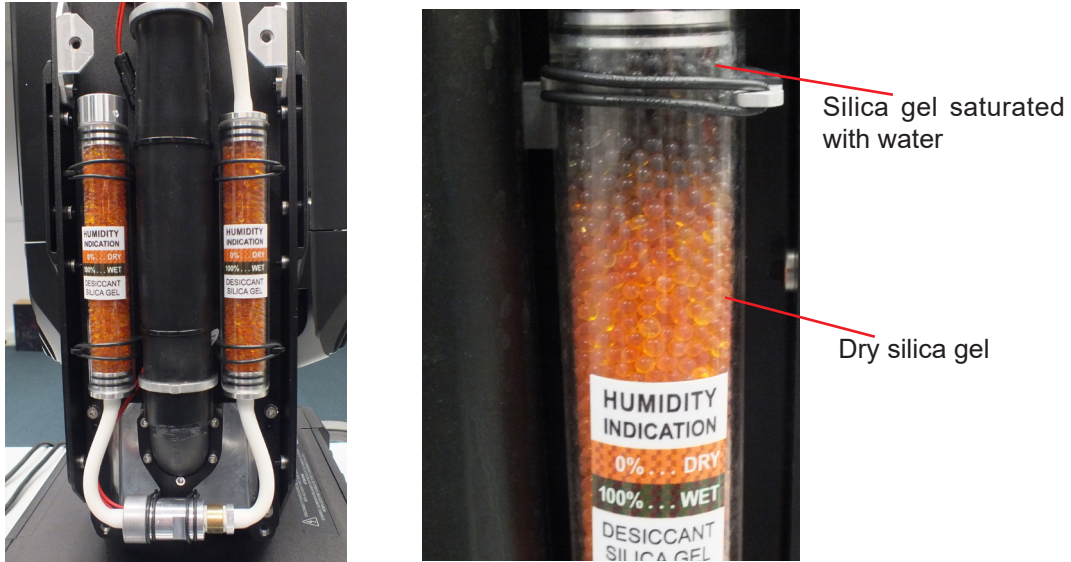

- State of desiccants in the fixture arm can be checked:
 - visually by unscrewing the cover of fixture arm
 - via fixture display (tab Information, option RAINS Status):

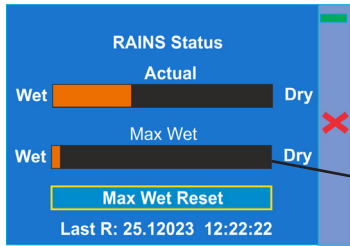

- remotely by means of the Robe Ethernet Access Portal (REAP):

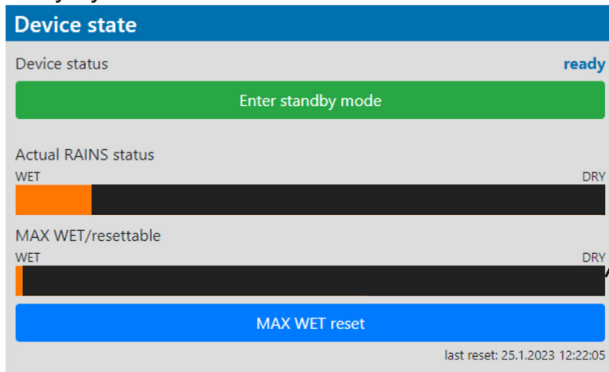

The chart MAX WET is decisive for replacing dessicants in the fixture arm. If the chart has changed to black colour, dessicants have to be replaced.

It is not necessary to replace silica gels dessicants in plastic boxes in the fixture head and base. These dessicants should be checked (and replaced if it is needed) at removing head or base covers, e.g. at gobo replacement or some service intervention.

In case that silica gel in the fixture arm is fully saturated with water, the warning message "**Too Much Humidity in Device**" will appear on the fixture display (yellow warning icon) and also in the Robe Ethernet Access Portal (Logs screen).

Example



14.5 Disposing of the product

To preserve the environment please dispose or recycle this product at the end of its life according to the local regulations and codes.

15. Obtaining information about the LED light source by mobile phone

You can read information about the LED light source by means of the mobile application ROBE COM. The LED light source has to be outside of the fixture.

Download and install the application ROBE COM from Google Play (for Android 7.1 and higher) or App Store (for iOS 15.0 and higher) to your mobile phone. Your mobile phone has to support NFC (Near-Field Communication).

After installing the ROBE COM, run the application by touching the icon  .
The following screen will appear:

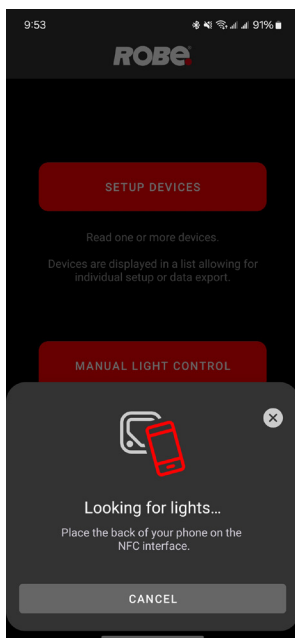

Hold the mobile phone close to the point of the LED light source PCB which is marked with the symbol NFC.

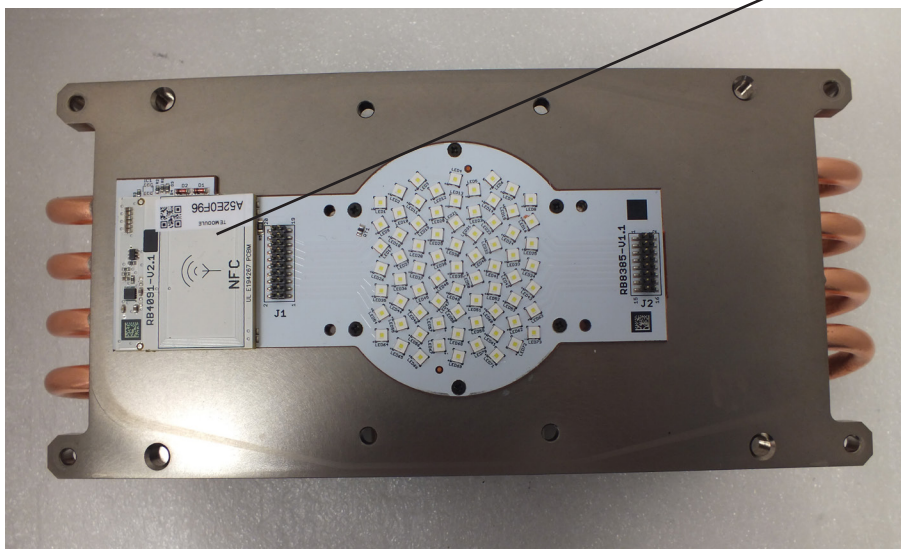

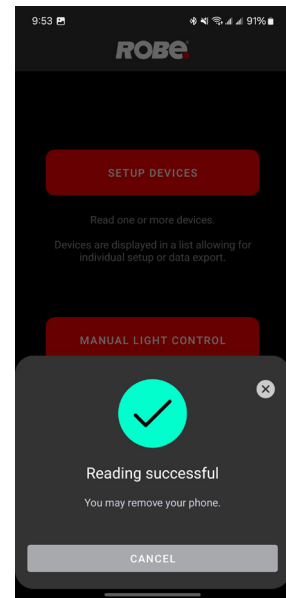
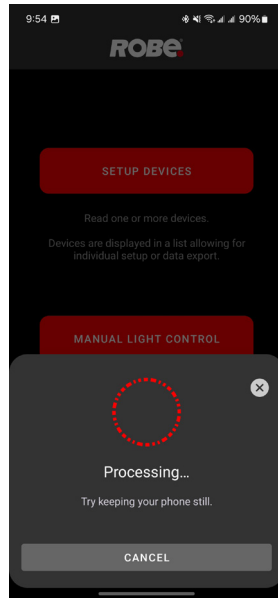
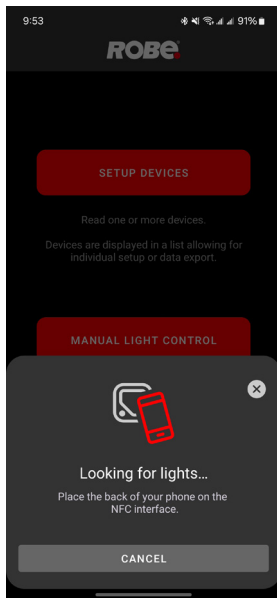

If NFC connection is OK, touch the item "SETUP DEVICES", then "Robin iEsprite LED module" and "LED engine" to read information about the LED module.

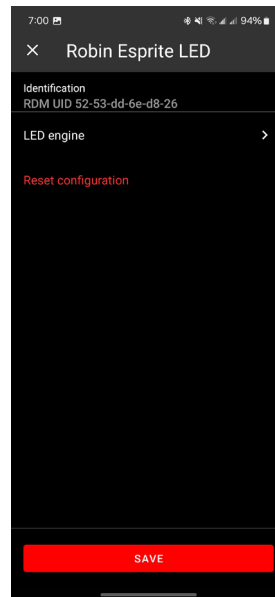
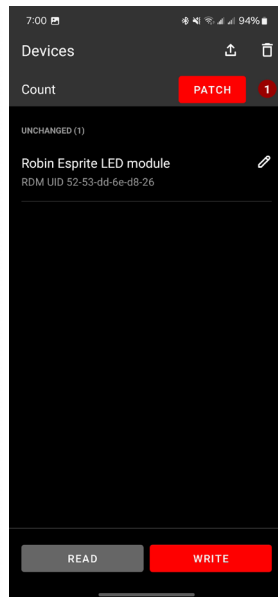
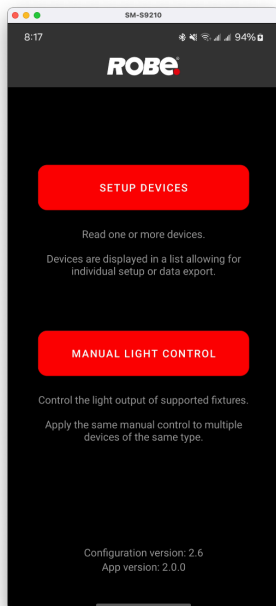

Note. The items "WRITE" and "SAVE" are not active. You can only read information from the LED light source.

16. Robe Ethernet Access Portal (REAP)

Before running the REAP, your computer needs to be connected to the fixture (s) through the means of Ethernet wired network and a network switch. The computer needs to have configured network settings in order to be able to communicate with the fixture(s) through the network. The Ethernet network connection (Local LAN) typically needs to be set to 2.x.x.x address, the computer IP address has to be set to 2.x.x.x (for example 2.249.20.10) with netmask 255.0.0.0. On the fixture make sure to use the default 2.x.x.x IP address as provided. You do not need change any IP settings on the fixture, there is no need to set the fixture into Art-Net mode.

Type the IP address of the iEsprite to your web browser, e.g. <http://2.249.20.10>, enter the user name: **robe** and the password: **2479**, the **Status screen** of the iEsprite will appear.

The screenshot shows the 'iEsprite LTL' status page. It features several panels:

- DMX/RDM settings:** DMX address: 1, DMX preset: Mode 1 (53 channels) wired, IP address: 2.249.20.10, MAC address: 00:0d:19:08:14:0a, RDM UID: 52:53:01:52:00:0a, RDM label: iEsprite LTL.
- Device times:** Power on time: 936h / 936h total / resettable, adaptive; LED on time total: 28h; LED on time adaptive: 19h.
- Device temperatures:** LEDs: 51°C / 95°C / 95°C; Driver: 55°C / 91°C / 90°C; Base: 48°C / 69°C / 69°C (current / maximum / resettable).
- Wireless state:** State: linked; Signal strength: 0.0%.
- Software versions:** List of modules (Display System, Module M, L, O, F-A, F-B, G, FR, C1, C2, DL) all at version 1.0 or 2.0.
- Device state:** Device status: active; Enter standby mode button; Current RAINS status: WET (orange bar); MAX WET/resettable: WET (orange bar); MAX WET reset button; last reset: 3.5.2025 22:31:02.
- Status messages:** Gobo Rotation error.

This screen gives you a fast overview of fixture settings and environment in the fixture. The icon  allows you to change some values in a corresponding table.

Example for DMX/RDM settings:

The screenshot shows the 'DMX/RDM settings' dialog box overlaid on the status page. The fields are:

- DMX address: 1
- DMX preset: Mode 1
- DMX input: wired
- RDM label: iEsprite LTL

 A 'Save' button is visible at the bottom right of the dialog.

Note.

The background colour of the top row of the Status screen with the name and RDM label of the fixture denotes state of the fixture:

-  fixture is ready for operation
-  fixture does not communicate with computer
-  fixture with error message(s)

The table "Device state" gives you information about fixture and environment in the fixture.

Device status: **ready** - all fixture resets successfully passed and the fixture is ready for operation.

initialization - fixture is waiting for fixture reset

heating - fixture is waiting for reaching operating temperature of the fixture inside (temperature in the fixture is below 0°C).

standby - the fixture is in standby mode

standby/heating - the fixture is in standby mode and inside of the fixture is heated

The bar chart **Actual RAINS status** informs you about current humidity in the fixture. The bar chart changes depending on humidity, temperature and pressure in the fixture. The bar chart depends on current conditions in the fixture and can be different at start of fixture operation, after 10 minutes of its operating, after closing fixture dimmer etc.

RAINS (Robe Automatic Ingress Neutralization System) manages humidity, temperature and pressure control using an active monitoring system to automatically remove any moisture detected within the fixture and provides permanent monitoring to ensure peak performance of the fixture.

The bar chart **MAX WET/resettable** informs you about maximum humidity achieved in the fixture since the chart was last reset. The bar chart also informs you about saturation of silica gel desiccants in the fixture arm with water and is deciding indicator for their checking and replacement.

The blue button **MAX WET reset** resets the bar chart MAX WET/resettable. Date and time of last reset is displayed below this button.

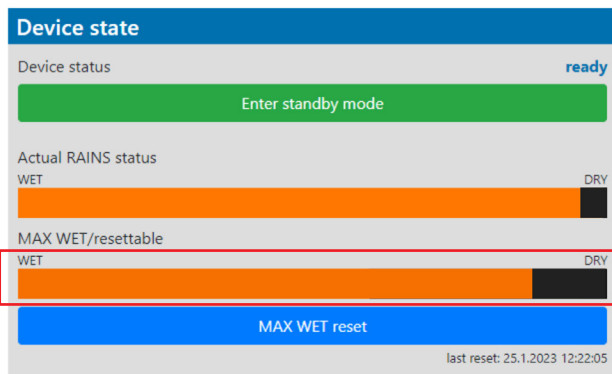

Silica gel desiccants in the fixture arm

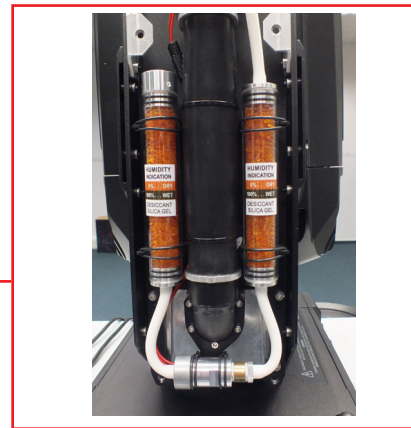

Examples of the table "Device state":

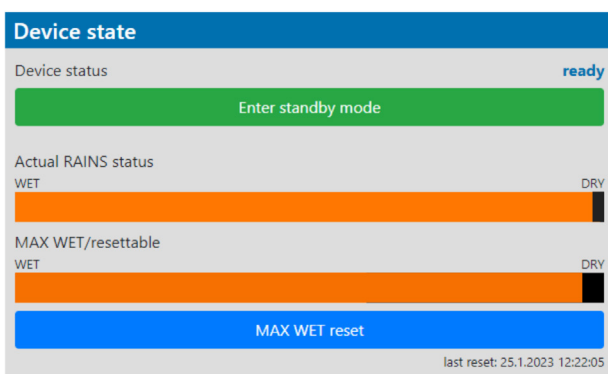

Dry desiccants

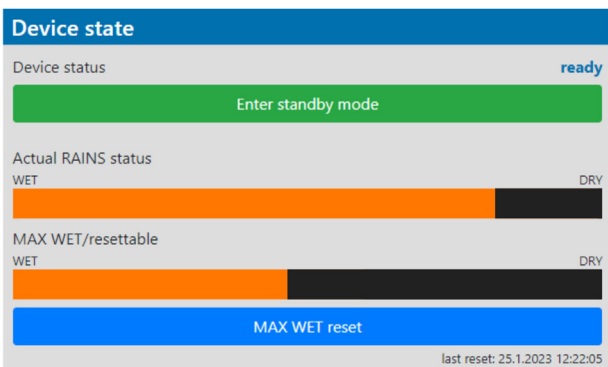

Desiccants partially saturated with water

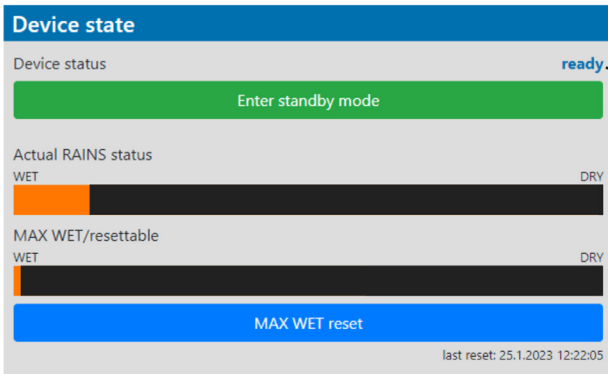

Device status **ready** means, that all fixture resets are OK and the fixture is ready for operation. It does not assess state of desiccants or result of pressure test!

Desiccants fully saturated with water

Silica gel desiccants in the fixture arm should be replaced.

After replacing them, reset MAX WET resettable bar chart.

It is not necessary to replace silica gels desiccants in plastic boxes in the fixture head and base. These desiccants should be checked (and replaced if it is needed) at removing head or base covers, e.g. at gobo replacement or some service intervention.

The option **Enter standby mode** allows you to switch the fixture to Standby mode.

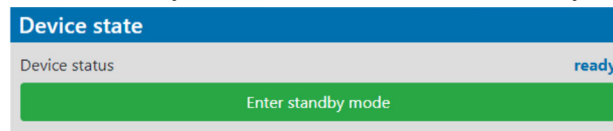

Note: Standby mode helps conserve power when a fixture is not in use, without fully powering it off. In the Standby mode, all fixture motors and fans are deactivated and light output is closed. For more information about Standby mode please see the chapter Standby mode.

The option **Escape standby mode** allows you to switch the fixture to the standard operating mode.

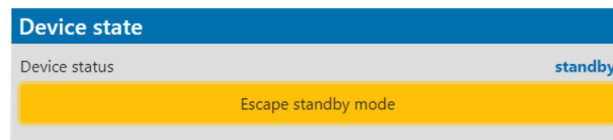

The **Personality** screen allows you to set fixture behaviour and run a pressure test.

The screenshot shows the ROBE Personality settings interface. It includes sections for DMX/RDM settings (Mode 1, wired), Ethernet settings (Ethernet mode: disable), Pan/Tilt settings (Pan reverse: off, Tilt reverse: off), Blackout settings (Active blackout while: off), Screen settings (Display intensity: 10), Color settings (Dimmer curve: square law), Date & time settings (Date: 3.5.2025), Other settings (Follow spot mode: off), and a Pressure test section with a green 'Start test' button.

The icon  allows you to change values in a corresponding table.

Example for Pan/Tilt settings:

This screenshot shows the Pan/Tilt settings modal open over the main settings screen. The modal contains:

- Pan reverse: off on
- Tilt reverse: off on
- Pan/Tilt feedback: off on
- Pan/Tilt Mode: speed time
- Pan/Tilt EMS: off on

 A blue 'Save' button is located at the bottom right of the modal.

The table "Pressure test " with green button **Start test** allows you to run a procedure which checks IP65 integrity of the fixture. The fixture has to be connected to mains and the head temperature (at pressure sensor) cannot be higher than 55°C. The pressure test lasts about 5 minutes and can be run at earliest 10 minutes after closing light output (shutter closed) of the fixture. The pressure test can be repeated at earliest 2 minutes after last pressure test.

This screenshot shows the Pressure test section after the test has been initiated. The green 'Start test' button has turned red and is now labeled 'Stop test'. Above the button, the text reads: 'Measurement Initialization (L.T. < 56 °C. Delay 09:56)'. The rest of the settings screen remains visible in the background.

Examples of pressure test messages:

Pressure test is 10 minutes delayed due to fixture cooling

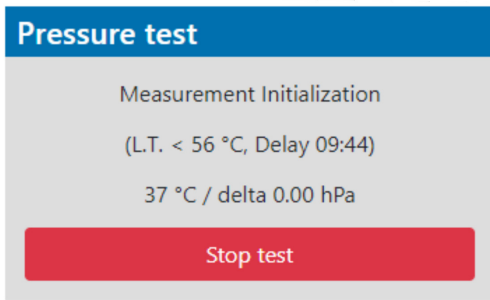

Pressure test is running

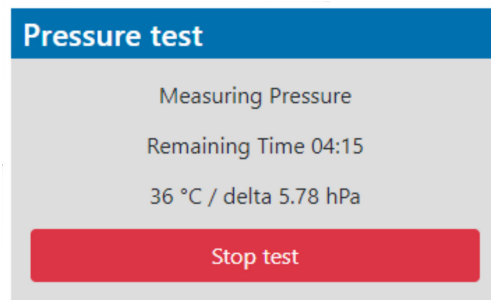

Pressure test passed

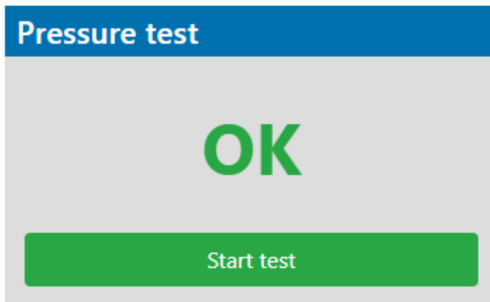

Pressure test failed

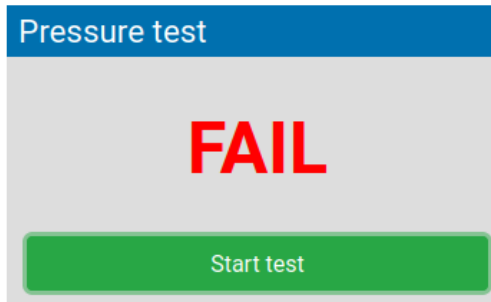

The **Logs screen** displays operating information of the fixture which have been saved.

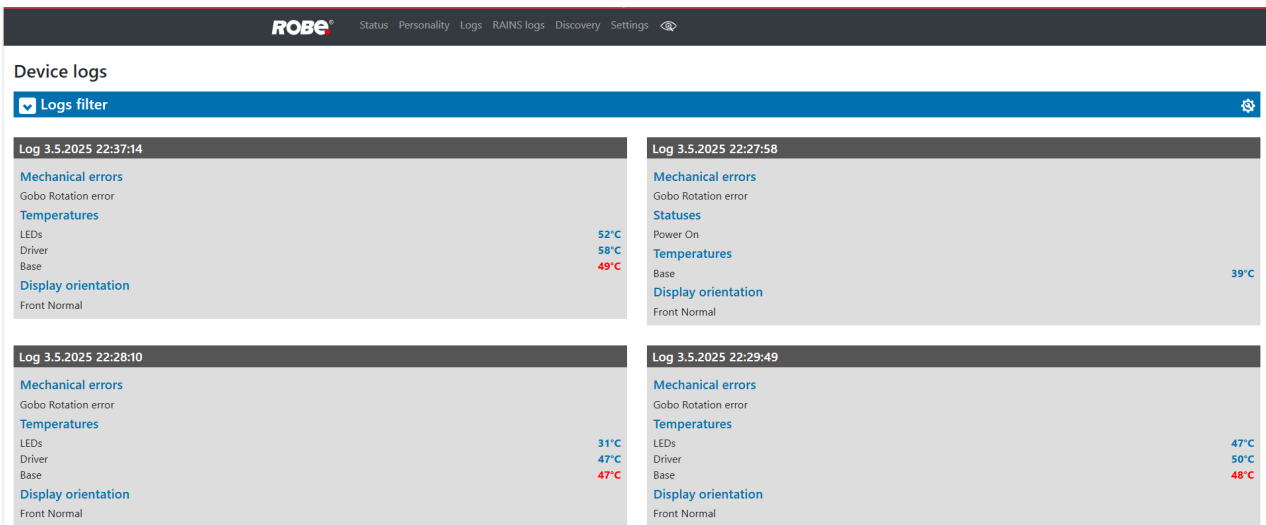

The icon  offers you two options:

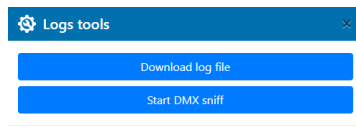

"Download log file" - the option allows you to download the log file to computer, name of the log file is: file-abcd.log, where abcd is a fixture ID (e.g. file-015e.log).

"Start DMX sniff" - the option starts saving coming DMX values to the file, the file name is DMX_sniffer.log). To stop the DMX sniffing, either stop generating the DMX signal on the console, or stop changing the DMX values. When the DMX signal is static for more the 3 seconds, the DMX Sniff will stop automatically. Do not stop the DMX Sniff by closing the download in the browser, it may save the file with incorrect data, always let the browser to self-close it when the DMX stops changing.

The option **Logs filter** allows you to select desired group of recorded errors and recorded operating values.

The screenshot shows the 'Device logs' page with a 'Logs filter' dropdown menu. The filter is currently set to 'all must pass'. Below the filter, four log entries are displayed, each showing a timestamp and a list of error types and temperatures for LEDs, Driver, and Base.

Expanded menu **Logs filter**

The screenshot shows the 'Expanded menu **Logs filter**' page. The menu is open, displaying various error categories like Mechanical errors, System errors, Statuses, and Temperatures, each with a list of sub-items and checkboxes. The 'all must pass' option is checked for each category. The 'Sorting, filter pass' section is also visible, with 'single groups' selected.

If the option "all must pass" is checked, only logs which contain all selected errors will be displayed.

Menu "Sorting filter pass" --> option "single groups" means that logs which contain at least one selected error will be displayed.

Menu "Sorting, filter pass" option "all groups" means that logs which contain all selected error will be displayed.

The **screen RAINS Logs** offers you a list of physical values recorded by sensors inside the head.

The screenshot shows the 'RAINS logs' page with the 'Sensors' tab active. The 'Logs filter' dropdown menu is open. Below the filter, a table displays recorded data for Date / Time, Temperature [°C], Relative humidity [%], and Pressure [hPa].

Date / Time	Temperature [°C]	Relative humidity [%]	Pressure [hPa]
3.5.2025 22:38:30	56	11.0	978
3.5.2025 22:35:38	55	11.0	978
3.5.2025 22:33:38	54	11.0	978
3.5.2025 22:27:49	53	11.0	978
3.5.2025 21:18:43	54	10.5	978
3.5.2025 21:18:41	53	10.5	978
3.5.2025 06:24:42	55	16.0	979
3.5.2025 05:31:07	54	17.0	980
3.5.2025 05:01:39	53	17.5	980
3.5.2025 04:43:06	52	18.5	980

You can select range of temperature, humidity and pressure in desired time interval.

RAINS logs

Sensors | Pressure measurements

Logs filter

Start date: dd. mm. rrrr | End date: dd. mm. rrrr

Temperature: - | °C

Relative humidity: - | %

Pressure: - | hPa

Buttons: Apply filter, Clear filter, Download log file

Date / Time	Temperature [°C]	Relative humidity [%]	Pressure [hPa]
3.5.2025 22:38:30	56	11.0	978
3.5.2025 22:35:38	55	11.0	978
3.5.2025 22:33:38	54	11.0	978

Tab Pressure measurements shows history of pressure tests.

Sensors

Sensors logs | Pressure measurements

Buttons: Download measurements file

Date / Time	Temperature [°C]	Relative humidity [%]	Pressure [hPa]	Pressure difference [hPa]	Duration [ms]	Result
14.4.2023 08:35:30	30	14.5	976	7.47	01:48	OK
9.2.2023 12:57:57	49	8.5	1010	7.34	02:22	OK
9.2.2023 12:44:03	47	10.0	1010	7.38	02:16	OK

If you have two and more iEsprites, the **Discovery** screen allows you to show all connected iEsprites in network. Click on the blue button **Discover** and fixtures connected in the network will be displayed.

Discovery

Move devices with warning to top

Columns selection (max. 7 items)

DMX address DMX preset RDM UID IP address Head temperature [°C] Relative humidity [%] RAINS (max wet) Last pressure test Device status

Buttons: Discover (4), Apply selection

Device	DMX address	DMX preset	RDM UID	IP address	RAINS (max wet)	Device status
iEsprite LTL	1	Mode 1 (53 channels)	52:53:01:52:00:0a	2.249.20.10	[Orange bar]	active
iForte - iForte 3	1	Mode 1 (54 channels)	52:53:01:2c:00:1a	2.247.136.26	[Black bar]	active
iEsprite	1	Mode 1 (49 channels)	52:53:01:32:00:38	2.247.184.56	[Orange bar]	active
iTetra2	1	Mode 6 (128 channels)	52:53:01:34:00:2a	2.247.216.42	[Black bar]	active

The background colour in the device row denotes state of the fixture:

- indicates "server fixture"(fixture of which IP address you have written to your WEB browser).
- indicates fixture ready for operation.
- indicates fixture which does not communicate with computer or "server fixture".
- indicates fixture with error messages.

Example: Fixtures which do not communicate with computer are indicated by yellow background.

Discovery

Move devices with warning to top

Columns selection

DMX address DMX preset RDM UID IP address Head temperature [°C] Relative humidity [%] RAINS (max wet) Last pressure test Device status

Device	DMX address	DMX preset	RDM UID	IP address	RAINS (max wet)	Device status
iEsprite	1	Mode 3 (50 channels)	52:53:01:32:00:0b	2.247.184.11		ready
iSpider	1	Mode 1 (49 channels)	52:53:01:1c:00:0e	2.246.236.14		active
iForte - iForte 3	1	Mode 1 (54 channels)	52:53:01:2c:00:1a	2.247.136.26		active

If the option Move devices with warning to top is checked, fixtures with some error will be displayed on the top of fixture list.

The option Columns selection allows you to check desired items which will be displayed in columns. Max. 6 items can be selected. After checking desired items, click on the blue button Apply selection to activate selection. Icons allows you to order values in the column in descending or ascending order. Note: The values of the fixture in the first blue row ("server fixture") will not be included into ordering.

Example.

Device	DMX address	DMX preset	RDM UID	IP address	RAINS (max wet)	Device status
iEsprite	1	Mode 3 (50 channels)	52:53:01:32:00:0b	2.247.184.11		ready
iSpider	1	Mode 1 (49 channels)	52:53:01:1c:00:0e	2.246.236.14		active
iForte - iForte 3	1	Mode 1 (54 channels)	52:53:01:2c:00:1a	2.247.136.26		active

Item **ready** in the column Device status does not assess state of desiccants or result of pressure test!

The **screen Settings** allows you to change password to REAP.

Site settings

Password settings

Old password

New password

New password check

Save

The icon serves for identification of the fixture in a group of fixtures. After clicking on the icon, the fixture's head will start to move.

17. Technical Specifications

Electrical

Power supply: electronic auto-ranging
 Input voltage range: 100-240V, 50-60Hz
 Fuse: T 12 A
 Inrush current: < 24A @ 230Vac (cold start)
 Max. power consumption: 950W (Power factor 0.96)

Optic

Light source: TE™ 750W XP White LED Engine (Transferable)
 Colour temperature: 6700K
 CRI: 70/80/90, remotely selectable
 Light source warranty: 4 years or 20 000 hours
 Light sources available: TE™ 750W HCF LED Engine (6000K, 97 CRI)

Colour wheel 1

five dichroic filters (deep red, deep blue, orange, green, congo blue) + open

Colour wheel 2

one multicolour filter, two dichroic filters (lavender, laser green), CRI filter 80, CRI filter 90 + open

CMY + CTO mixing module

Smooth CMY colour mixing system
 Variable CTO: 3000K - 6.700K

Virtual colour wheel

66 preset colours

Effect wheel

Aluminium effect wheel rotating in both directions with variable speed

Static gobo wheel

9 replaceable gobos, outside diameter: 26.8^{+0.1} mm, image diameter=18 mm, high temperature borofloat or better glass, thickness=1.1 mm
 Gobo wheel continuous rotation

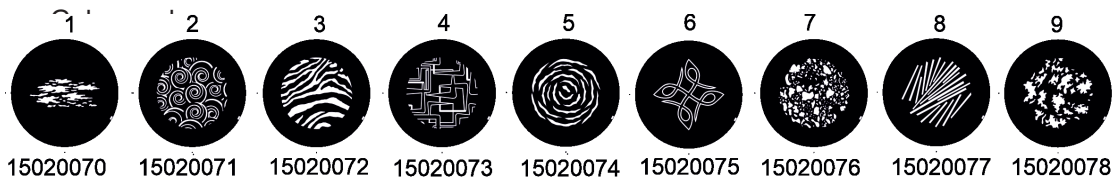

Note. Steel (or aluminium) gobos cannot be used due to thermal stress.

Rotating gobo wheel

7 replaceable gobos can be indexed and rotated in both directions at different speeds
 Gobo carousel continuous rotation,
 Gobos: outside diameter= 21.3^{+0.1} mm, image diameter=18 mm, thickness=1.1mm, high temperature borofloat or better glass. Do not use steel gobos
 "Slot&lock" system for easy replacement of gobos
 Gobos order:

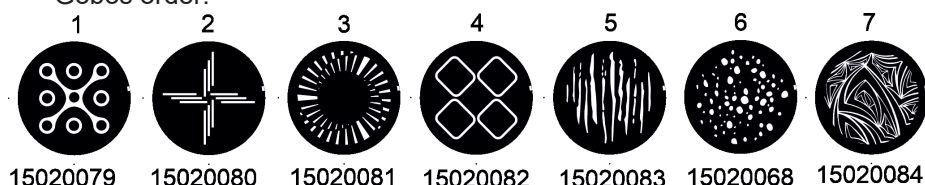

Note. Steel (or aluminium) gobos cannot be used due to thermal stress.

Prism 1

Rotating 6-facet linear prism with continuous rotation in both directions and indexing

Prism 2

Rotating 6-facet circular prism with continuous rotation in both directions.

Iris

Motorized iris for different beam diameters

Frost filters

Two separate, variable frost filters (light (1°) and medium (5°))
Both filters are replaceable

Framing shutters module

4 individually positionable blades plus rotation of the complete frame system +/- 60°
Each framing shutter can be swiveled by +/- 30°

Zoom

Linear motorized zoom
3° - 57° (standard optical range)
2° - 57° (using optical zoom + iris)
0.6° - 2° (Long Throw mode)

Strobe

Strobe effect with variable speed (0.3 - 20Hz)

Dimmer

Smooth dimmer from 0 - 100 % (8 or 16 bit (internal 18 bit))

Camera (Robin iEsprite LTL FS only)

Type: XNZ-L6320A
Max. resolution: 1920 x 1080
16 : 9 Full HD (1080p) resolution support
32x optical zoom, 32x digital zoom
Streaming: H.264, H265, MJPEG codec, Multiple streaming
Vision: Day & Night (ICR), WDR (120dB), Defog
Minimum illumination: 0.05 lux

Control

Graphic screen for fixture setting and addressing
Gravitation sensor for auto screen positioning
Electronic Motion Stabilizer system for Pan & Tilt (EMS™)
Automatic Pan/Tilt position correction
Motionless absolute positioning system for Pan and Tilt (MAPS™)
Built-in demo sequences
Stand-alone operation
1 user editable program up to 80 steps
Supported protocols: USITT DMX 512-A, RDM, RDMnet, ArtNet, MANet, MANet2, sACN
Support of RDM (Remote Device Management)
One DMX mode (53 control channels)

Wireless DMX/RDM module type RW 001 (only wireless DMX version of the fixture)

Supported protocols: full RDM support, CRMX , W-DMX™ G2, G3, G4 and G4S
Operational frequency range: 2402-2480 MHz
Output power: 100 mW
Receiver sensitivity (0.1% BER): -93 dBm
Crystal Clock Frequency : 16.0 MHz

Max. number of fixtures in Ethernet IN/Out line

8

Battery

Size: AA (R6)
Type: IFR 1450, 600mA/3.2V

Pan/Tilt

Pan movement range 540°
Tilt movement range 270°
16-bit movement resolution
Electronic Motion Stabilizer system for Pan & Tilt (EMS™)
Motionless absolute positioning system for Pan and Tilt (MAPS™)
Automatic Pan/Tilt position correction
Remotely controllable speed of pan/tilt movement for easy programming
Pan/tilt-lock mechanism

Rigging

Mounting points: 4 pairs of 1/4-turn locking points
Mounting horizontally or vertically via 2 Omega brackets

Connection

DMX data in/out: 2 x IP65 Locking 5-pin XLR connector Seetronic
Ethernet: 2 x IP65 RJ45 connector Seetronic
Power: IP65 power connector Seetronic
Camera output: IP65 RJ 45 connector Seetronic

Temperatures

Minimum/Maximum ambient operating temperature : -30°C/+45°C
Maximum housing temperature : 80° C

Minimum distances

Min. distance from flammable surfaces: 1 m
Min. distance to lighted object: 5 m

Total heat dissipation

max. 2430 BTU/hr (calculated)

Ingress protection rating

IP65

Desiccants

Total weight of all silica gel fillings in the fixture is 207 g

Weight

37 kg (81.6 lbs)

Dimensions (mm) - iEsprite LTL WB

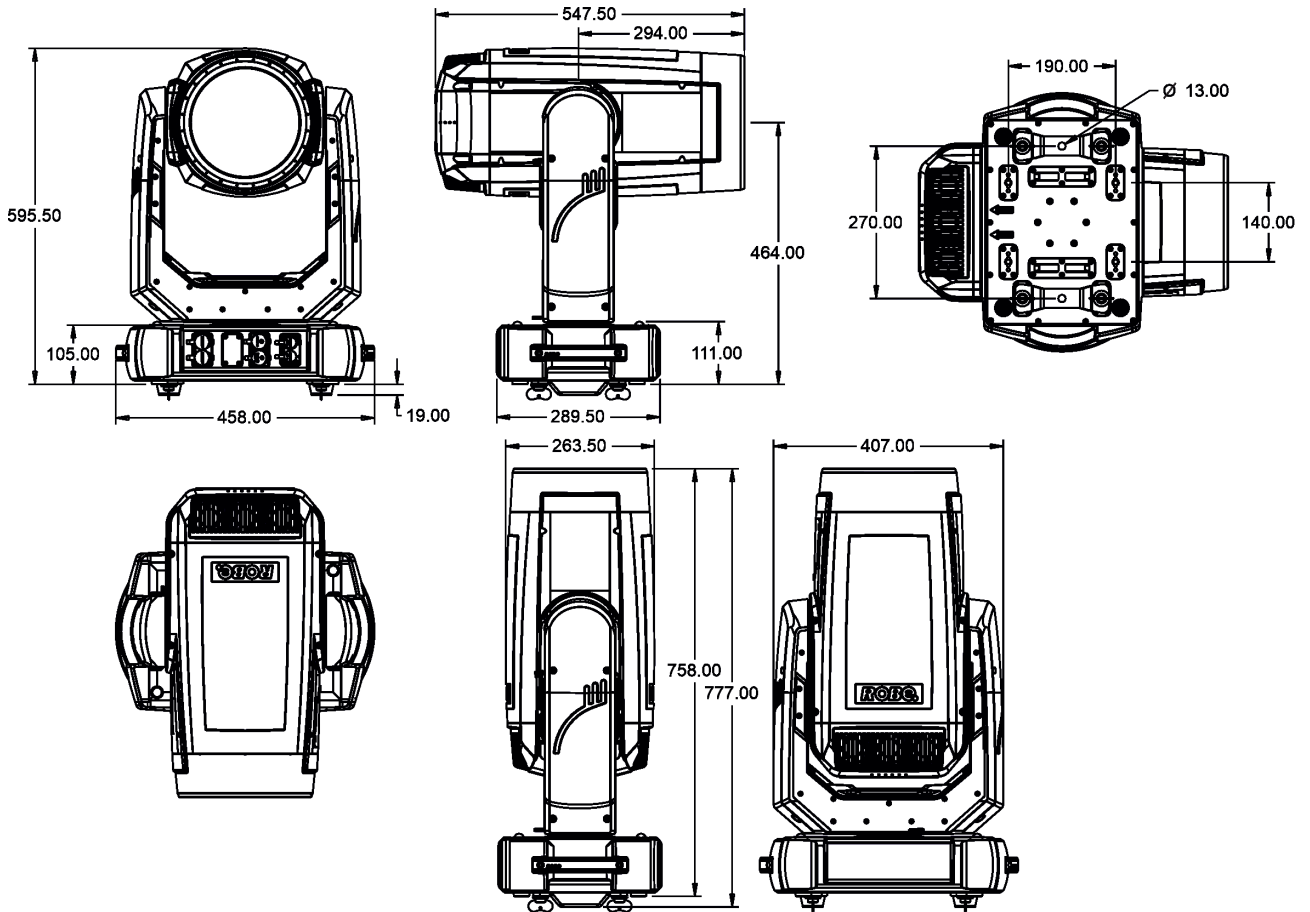

Dimensions (mm) - iEsprite LTL FS

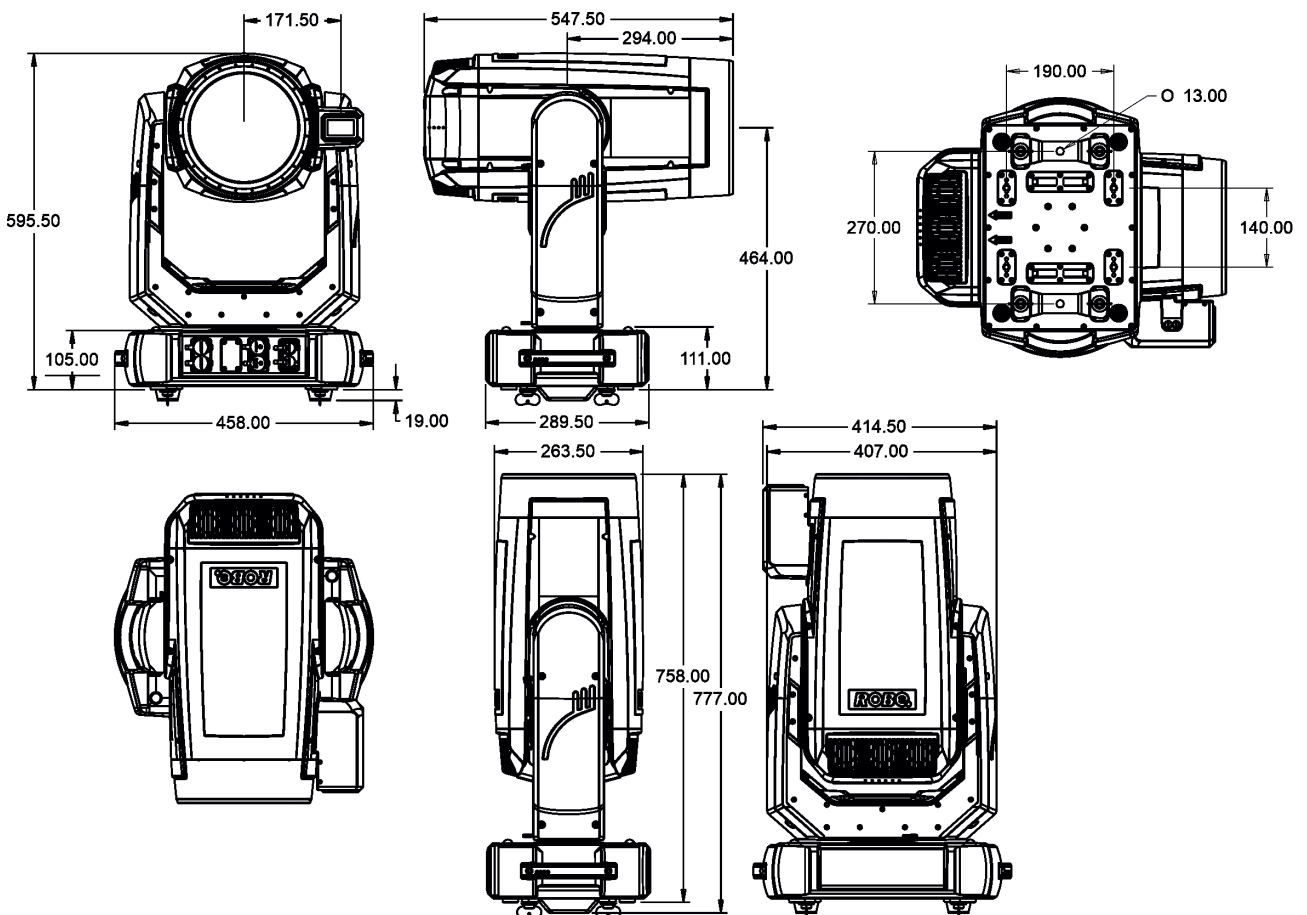

Accessories

iEsprite LTL WB

- 1 x Omega adaptor CL-regular 2 pcs in box (P/N 10980033)
- 1 x Power cable including powerCON TRUE1 In connector (IP 65 rating)

iEsprite LTL FS

- 1 x Omega adaptor CL-regular 2 pcs in box (P/N 10980033)
- 1 x Power cable including powerCON TRUE1 In connector (IP 65 rating)
- 1 x Camera (installed on the fixture)
- 1 x FS LTL, LTX Balancing Weight Cover for CamFit (P/N 10981009)

Optional accessories

- Frost 0.5° (exchange) assembled (P/N 10980583)
- Frost 10° (exchange) assembled (P/N 10980497)
- Frost 20° (exchange) assembled (P/N 10980574)
- Frost 30° (exchange) assembled (P/N 10980584)
- Doughty Trigger Clamp (P/N 17030386)
- Safety wire 50 kg (P/N 99011957)
- Removable handle size L 2pcs (P/N 10981219)
- FS LTL, LTX CamFit kit (P/N 10980885)
- iEsprite LTL WB iSE-TE™ 750W XP White LED Engine (P/N 14080103)
- iEsprite LTL WB iSE-TE™ 750W HCF White LED Engine (P/N 14080108)
- Robin iEsprite LTL LightMaster side kit SET (P/N 10080397)
- WTF!/iESPRITE LTL 400mm Truss mounting plate (P/N 10981427)

18. ChangeLog

This section summarizes changes in the user manual.

Version of the manual	Date of issue	Description of changes
1.1	13/11/2025	iSE-TE™ 750W HCF White LED Engine added to optional accessories
1.2	08/12/2025	Static pan/tilt reset On/Off added
1.3	29/01/2026	Menu Pan/tilt Speed added

January 29, 2026

Copyright © 2024-2026 Robe Lighting - All rights reserved

All Specifications subject to change without notice

Made in CZECH REPUBLIC by ROBE LIGHTING s.r.o. Palackeho 416/20 CZ 75701 Valasske Mezirici



Robin iESPRITE®LTL WB/ROBIN iESPRITE®LTL FS - DMX protocol		
Version: 1.3 Mode 1 - Standard 16 bit		
Quick overview of default DMX values for each channel		
Mode/channel	Default DMX Value	Function
1		
1	128	Pan
2	0	Pan Fine
3	128	Tilt
4	0	Tilt fine
5	0	Pan/Tilt speed , Pan/Tilt time
6	0	Power/Special functions
7	10	LED frequency selection
8	128	LED frequency fine adjusting
9	0	Max. light intensity indication and setting
10	0	Colour wheel 1
11	0	Colour wheel 1-fine positioning
12	0	Colour wheel 2
13	0	Colour wheel 2-fine positioning
14	0	Cyan
15	0	Magenta
16	0	Yellow
17	0	CTO
18	128	Green Correction
19	0	Virtual colour wheel
20	0	Effects speed
21	0	CMY+CTO+Colour wheels time
22	0	Static gobo/ Framing shutters/Zoom/Focus/Iris/Frost/Prism time
23	0	Effect wheel positioning
24	128	Effect wheel rotation
25	0	Effect wheel animations
26	0	Static gobo wheel
27	0	Rotating gobo wheel
28	0	Rotating gobo wheel- fine positioning
29	128	Rot. gobo indexing and rotation
30	0	Rot. gobo indexing/rotation - fine
31	0	Prism 1
32	128	Prism 1 indexing/rotation
33	0	Prism 2
34	128	Prism 2 rotation
35	0	Frost
36	0	Iris
37	0	Iris - fine
38	128	Zoom
39	0	Zoom - fine
40	128	Focus
41	0	Focus - fine
42	128	Framing shutters module rotation
43	0	Framing shutter 1- movement

DMX protocol

Mode/channel	Default DMX Value	Function	
1			
44	128	Framing shutter 1- swivelling	
45	0	Framing shutter 2- movement	
46	128	Framing shutter 2- swivelling	
47	0	Framing shutter 3 movement	
48	128	Framing shutter 3- swivelling	
49	0	Framing shutter 4 movement	
50	128	Framing shutter 4- swivelling	
51	32	Shutter/ strobe	
52	0	Dimmer intensity	
53	0	Dimmer intensity - fine	
Mode/channel	DMX Value	Function	Type of control
1		Pan	
	0 - 255	Pan movement by 540° (128=default)	proportional
2		Pan Fine	
	0 - 255	Fine control of pan movement (0=default)	proportional
3		Tilt	
	0 - 255	Tilt movement by 265° (128=default)	proportional
4		Tilt fine	
	0 - 255	Fine control of tilt movement (0=default)	proportional
5		Pan/Tilt speed , Pan/Tilt time	
	0	Standard mode (0=default)	step
	1	Max. Speed Mode	step
		<i>Pan/Tilt speed mode</i>	
	2 - 255	Speed from max. to min.	proportional
		<i>Pan/Tilt time mode</i>	
	2 - 255	Time from 0.2 sec. to 25.5 sec.	proportional
6		Power/Special functions	
		Factory display menu setting: DMX Input-Wired ,Graphic display-On, Pan/tilt Mode-Speed,Blackout while pan/tilt moving-Off, Blackout while gobo wheels moving-Off,Blackout while colour wheels moving-Off, Fans mode-Auto, High-power mode - Off, Focus Tracking- Off, Gobo transition - Maximum speed and shortcut	
	0 -5	Reserved (0=default)	
		<i>To activate following functions, stop in DMX value for at least 3 s and shutter must be closed at least 3 sec. (Channel „Shutter/ Strobe“ 51 must be at range: 0-31 DMX). Corresponding menu items are temporarily overwritten.</i>	
	6	Standby mode: On (fixture effects are deactivated, light output is closed)	step
	7	Standby mode: Off	step
	8	Pressure test: On (fixture does not respond to DMX during the test except value 9 (Pressure test Off))	step
	9	Pressure test: Off	step
	10-14	DMX input: Wired DMX *	step
	15-19	DMX input: Wireless DMX *	step

DMX protocol

Mode/channel	DMX Value	Function	Type of control
1			
		* function is active only 10 seconds after switching the fixture on	
	20-24	Graphic display: On	step
	25-29	Graphic display: Off	step
	30-31	Quiet mode: Fans On at blackout	step
	32-33	Quiet mode: Fans Off at blackout	step
	34-35	Dimmer curve: Super Square Law	step
	36-37	Pan/Tilt speed Max. - base horizontal (default setting in fixture)	step
	38-39	Pan/Tilt Speed Reduced - base vertical	step
	40-44	Pan/Tilt mode: Speed	step
	45-49	Pan/Tilt mode: Time	step
	50-54	Blackout while pan/tilt moving: On	step
	55-59	Blackout while pan/tilt moving: Off	step
	60-64	Blackout while gobo wheels moving: On	step
	65-69	Blackout while gobo wheels moving: Off	step
	70-74	Blackout while colour wheels moving: On	step
	75-79	Blackout while colour wheels moving: Off	step
	80-84	Fans mode: Auto	step
	85-89	Fans mode: High	step
	90-99	Reserved	
	100-104	Focus Tracking: On	step
	105-109	Focus Tracking: Off	step
	110-114	Dimmer curve: Square law	step
	115-119	Dimmer curve: Linear	step
	120-124	Parking position: On	step
	125-129	Parking position: Off	step
		<i>To activate following functions, stop in DMX value for at least 3 seconds.</i>	
	130 - 139	Total fixture reset (without pan/tilt)	step
	140 - 149	Pan and Tilt reset	step
	150 - 159	Colour system reset	step
	160 - 169	Gobo wheels/effect wheel reset	step
	170-174	Pan reset	step
	175-179	Tilt reset	step
	180 - 189	Zoom/focus/frost/prisms reset	step
	190 - 199	Iris /framing shutters reset	step
	200 - 209	Total fixture reset (including pan/tilt)	step
	210	Static Pan/Tilt reset: On** (default setting in the fixture)	step
	211	Static Pan/Tilt reset: Off**	step
	212	Calibrate Pan/Tilt reset	step
		<i>** Set option will be saved to the fixture.</i>	
	213 - 218	Reserved	
		The following three commands define transition from gobo rotation to gobo indexing:	
	219 - 220	Gobo indexing: Maximum speed and shortcut	step
	221 - 222	Gobo indexing: Follow speed and direction	step
	223 - 224	Gobo indexing: Maximum speed and follow direction	step
		The following RoboSpot related commands are only applicable when the RoboSpot is connected:	
	225 - 229	RoboSpot enabled	step

DMX protocol

Mode/channel	DMX Value	Function	Type of control
1	230 - 234	RoboSpot disabled - except handle faders and pan/tilt	step
	235 - 239	RoboSpot fully disabled	step
	240	Disabled "Quiet mode"	step
	241 - 255	Quiet mode - fan noise control from min. to max.	proportional
7		LED frequency selection	
		Factory display menu setting: 600Hz	
		<i>Select PWM output frequency of LEDs. Selected PWM frequency can be fine adjusted in 127 steps up/down around selected PWM frequency on the channel below. Corresponding menu item (Frequency Setup) is temporarily overridden.</i>	
	0-4	PWM frequency from Display menu (fixture utilizes PWM frequency set in the display menu item Frequency Setup).	step
	5-9	300 Hz	step
	10-14	600 Hz (10=default)	step
	15-19	1200 Hz	step
	20-24	2400 Hz	step
	25-255	Reserved (fixture utilizes PWM frequency set in the display menu item Frequency Setup).	
8		LED frequency fine adjusting	
		Factory display menu setting: 600Hz	
		<i>Select desired PWM output frequency of LEDs on the channel above.</i>	
	0-1	Selected LED Frequency	step
	2	LED Frequency (step -126)	step
	3	LED Frequency (step -125)	step
	4	LED Frequency (step -124)	step
	:		
	125	LED Frequency (step -3)	step
	126	LED Frequency (step -2)	step
	127	LED Frequency (step -1)	step
	128	Selected LED Frequency (128=default)	step
	129	LED Frequency (step +1)	step
	130	LED Frequency (step +2)	step
	131	LED Frequency (step +3)	step
	:		
	252	LED Frequency (step +124)	step
	253	LED Frequency (step +125)	step
	254	LED Frequency (step +126)	step
	255	Selected LED Frequency	step
9		Max. light intensity indication and setting	
	0-10	No function (0=default)	
	11-20	Indication of drop of max. light intensity	step
		<i>A drop of max. light intensity of the fixture (compared to its original intensity) is indicated by a corresponding colour output:</i> <i>0-5%, (WHITE /new LED module/)</i> <i>6-10% (RED)</i> <i>11-15% (GREEN)</i> <i>16-20% (BLUE)</i> <i>21-25% (CYAN)</i>	

DMX protocol

Mode/channel	DMX Value	Function	Type of control
1		26-30% (MAGENTA) 31-35% (YELLOW) 36-40% (ORANGE) Pan/tilt/zoom is set at 128 DMX (50%), Dimmer is open at 255 DMX (100%). <i>To set a drop of max. light intensity (compared to original light intensity), stay at DMX value for at least 3 sec. and shutter must be closed at least 3 sec. (Channel „Shutter/Strobe“ 47/41 must be at range: 0-31 DMX). Corresponding menu items are permanently overwritten.</i>	
	21-30	Set drop by 6-10% (RED)	step
	31-40	Set drop by 11-15% (GREEN)	step
	41-50	Set Drop by 16-20% (BLUE)	step
	51-60	Set drop by 21-25% (CYAN)	step
	61-70	Set drop by 26-30% (MAGENTA)	step
	71-80	Set drop by 31-35% (YELLOW)	step
	81-90	Set drop by 36-40% (ORANGE)	step
	91-100	Original intensity (WHITE)	step
	101-255	Reserved	
10		Colour wheel 1	
		Continual positioning	
	0	Open/white (0=default)	proportional
	21	Deep red	proportional
	43	Deep blue	proportional
	64	Orange	proportional
	86	Green	proportional
	107	Congo blue	proportional
	128-129	Open/White	step
		Positioning	
	130-141	Deep red	step
	142-153	Deep blue	step
	154-165	Orange	step
	166-177	Green	step
	178-189	Congo blue	step
	190 - 215	Forwards rainbow effect from fast to slow	proportional
	216 - 217	No rotation	step
	218 - 243	Backwards rainbow effect from slow to fast	proportional
	244 - 249	Reserved	
	250 - 255	Auto random colour selection from fast to slow	proportional
11		Colour wheel 1 - fine positioning	
	0 - 255	Fine positioning (0=default)	proportional
12		Colour wheel 2	
		Continual positioning	
	0	Open/white (0=default)	proportional
	21	Multicolour	proportional
	43	Laser green	proportional
	64	Lavender	proportional
	86	Filter CRI 80	proportional
	107	Filter CRI 90	proportional

DMX protocol

Mode/channel	DMX Value	Function	Type of control
1			
	128-129	Open/White	step
		Positioning	
	130-141	Multicolour	step
	142-153	Laser green	step
	154-165	Lavender	step
	166-177	Filter CRI 80	step
	178-189	Filter CRI 90	step
	190 - 215	Forwards rainbow effect from fast to slow	proportional
	216 - 217	No rotation	step
	218 - 243	Backwards rainbow effect from slow to fast	proportional
	244 - 249	Reserved	
	250 - 255	Auto random colour selection from fast to slow	proportional
13		Colour wheel 2 - fine positioning	
	0 - 255	Fine positioning (0=default)	proportional
14		Cyan	
	0 - 255	Cyan from min. saturation --> full cyan (0=default)	proportional
15		Magenta	
	0 - 255	Magenta from min. saturation --> full magenta (0=default)	proportional
16		Yellow	
	0 - 255	Yellow from min. saturation --> full yellow (0=default)	proportional
17		CTO	
	0 - 255	CTO from 6700K --> 2700K (0=default), XP white LED engine	proportional
		CTO from 5800K --> 2200K (0=default), HCF white LED engine	proportional
18		Green correction	
	0	Uncorrected white	step
	1-127	Minus green --> uncorrected white	proportional
	128	Uncorrected white (128=default)	step
	129-255	Uncorrected white --> Plus green	proportional
19		Virtual colour wheel	
		<i>See table "Colours on Virtual Colour Wheel" to find components of each colour</i>	
		<i>The following channels are disabled: 9-18</i>	
	0	No function (0=default)	step
	1-2	Filter 4 (Medium Bastard Amber)	step
	3-4	Filter 10 (Medium Yellow)	step
	5-6	Filter 19 (Fire)	step
	7-8	Filter 26 (Bright Red)	step
	9-10	Filter 58 (Lavender)	step
	11-12	Filter 68 (Sky Blue)	step
	13-14	Filter 71 (Tokyo Blue)	step
	15-16	Filter 79 (Just Blue)	step
	17-18	Filter 88 (Lime Green)	step
	19-20	Filter 90 (Dark Yellow Green)	step
	21-22	Filter 100 (Spring Yellow)	step
	23-24	Filter 101 (Yellow)	step
	25-26	Filter 102 (Light Amber)	step
	27-28	Filter 103 (Straw)	step
	29-30	Filter 104 (Deep Amber)	step

DMX protocol

Mode/channel	DMX Value	Function	Type of control
1			
	31-32	Filter 105 (Orange)	step
	33-34	Filter 106 (Primary Red)	step
	35-36	Filter 111 (Dark Pink)	step
	37-38	Filter 115 (Peacock Blue)	step
	39-40	Filter 116 (Medium Blue-Green)	step
	41-42	Filter 117 (Steel Blue)	step
	43-44	Filter 118 (Light Blue)	step
	45-46	Filter 119 (Dark Blue)	step
	47-48	Filter 120 (Deep Blue)	step
	49-50	Filter 121 (Filter Green)	step
	51-52	Filter 128 (Bright Pink)	step
	53-54	Filter 131 (Marine Blue)	step
	55-56	Filter 132 (Medium Blue)	step
	57-58	Filter 134 (Golden Amber)	step
	59-60	Filter 135 (Deep Golden Amber)	step
	61-62	Filter 136 (Pale Lavender)	step
	63-64	Filter 137 (Special Lavender)	step
	65-66	Filter 138 (Pale Green)	step
	67-68	Filter 139 (Primary Green)	step
	69-70	Filter 141 (Bright Blue)	step
	71-72	Filter 147 (Apricot)	step
	73-74	Filter 148 (Bright Rose)	step
	75-76	Filter 152 (Pale Gold)	step
	77-78	Filter 154 (Pale Rose)	step
	79-80	Filter 157 (Pink)	step
	81-82	Filter 158 (Deep Orange)	step
	83-84	Filter 162 (Bastard Amber)	step
	85-86	Filter 164 (Flame Red)	step
	87-88	Filter 165 (Daylight Blue)	step
	89-90	Filter 169 (Lilac Tint)	step
	91-92	Filter 170 (Deep Lavender)	step
	93-94	Filter 172 (Lagoon Blue)	step
	95-96	Filter 179 (Chrome Orange)	step
	97-98	Filter 180 (Dark Lavender)	step
	99-100	Filter 181 (Congo Blue)	step
	101-102	Filter 197 (Alice Blue)	step
	103-104	Filter 201 (Full C.T. Blue)	step
	105-106	Filter 202 (Half C.T. Blue)	step
	107-108	Filter 203 (Quarter C.T. Blue)	step
	109-110	Filter 204 (Full C.T. Orange)	step
	111-112	Filter 205 (Half C.T. Orange)	step
	113-114	Filter 206 (Quarter C.T. Orange)	step
	115-116	Filter 247 (Filter Minus Green)	step
	117-118	Filter 248 (Half Minus Green)	step
	119-120	Filter 281 (Three Quarter C.T. Blue)	step
	121-122	Filter 285 (Three Quarter C.T. Orange)	step
	123-124	Filter 352 (Glacier Blue)	step
	125-126	Filter 353 (Lighter Blue)	step

DMX protocol

Mode/channel	DMX Value	Function	Type of control
1	127-128	Filter 715 (Cabana Blue)	step
	129-130	Filter 778 (Millennium Gold)	step
	131-132	Filter 793 (Vanity Fair)	step
	133-255	Reserved	
20		Effects Speed <i>Speed of CMY&CTO movement and Rot. Gobo/Static Gobo selection</i>	
	0-255	Speed of CMY+CTO movement from max. to min. (0=default)	proportional
	0-255	Speed of Rot. Gobo/Stat. Gobo selection from max. to min.	proportional
21		CMY+CTO+Colour wheels time	
	0	Function is off (0=default)	step
	1 - 255	Time of CMY, CTO and Colour wheels movement (0.1sec-->25.5sec.)	proportional
22		Static gobo wheel/ Framing shutters/Zoom/Focus/Iris/Frost/Prisms time	
	0	Function is off (0=default)	step
	1-255	Time of static gobo movement (0.1 sec-->25.5 sec.)	proportional
	1 - 255	Time of framing shutters, zoom, focus, iris and frost movement (0.1 sec-->25.5 sec.)	proportional
	1-50	Time of prisms movement (0.1 sec-->5 sec.)	proportional
23		Effect wheel positioning	
	0-19	No function (0=default)	step
	20-127	Proportional indexing (73-center)	proportional
	128-170	Ramping from open to full position (max--->min. speed)	proportional
	171-213	Ramping from open to half position (max. --->min. speed)	proportional
	214-255	Ramp. from half position to full position (max. --->min. speed)	proportional
24		Effect wheel rotation	
	0	No rotation	step
	1 - 127	Rotation from fast to slow - CW (clockwise)***	proportional
	128	No rotation (128=default)	step
	129 - 255	Rotation from slow to fast CCW (counterclockwise)***	proportional
25		Effect wheel animations	
	0-7	No animation (0=default) <i>Note : Set suitable DMX value at Focus channel to get desired animation. All animations were created at distance of 5 m from screen with zoom=128 DMX, Focus value is different for each effect (focus value is stated in parentheses for this distance)</i> <i>The following channels are blocked: Effect wheel positioning, Effect wheel rotation,Static gobo wheel. Rotating gobo wheel, Rot. Gobo indexing and rotation, Rot. Gobo wheel fine rotation.</i>	
	8-9	Macro 1 (Focus=162)	step
	10-11	Macro 2 (Focus=201)	step
	12-13	Macro 3 (Focus=141)	step
	14-15	Macro 4 (Focus=159)	step
	16-17	Macro 5 (Focus=168)	step
	18-19	Macro 6 (Focus=168)	step
	20-21	Macro 7 (Focus=168)	step
	22-23	Macro 8 (Focus=168)	step
	24-25	Macro 9 (Focus=147)	step
	26-27	Macro 10 (Focus=147)	step
	28-255	Reserved	

DMX protocol

Mode/channel	DMX Value	Function	Type of control	
1				
26		Static gobo wheel		
	0-8	Open/hole (0=default)	step	
	9-17	Gobo 1	step	
	18-26	Gobo 2	step	
	27-35	Gobo 3	step	
	36-44	Gobo 4	step	
	45-53	Gobo 5	step	
	54-62	Gobo 6	step	
	63-71	Gobo 7	step	
	72-80	Gobo 8	step	
	81-91	Gobo 9	step	
			<i>Shaking gobos from slow to fast</i>	
	92-103	Gobo 1	proportional	
	104-115	Gobo 2	proportional	
	116-127	Gobo 3	proportional	
	128-139	Gobo 4	proportional	
	140-151	Gobo 5	proportional	
	152-163	Gobo 6	proportional	
	164-175	Gobo 7	proportional	
	176-187	Gobo 8	proportional	
	188-199	Gobo 9	proportional	
	200 - 201	Open/hole	step	
	202 - 222	Forwards gobo wheel rotation from fast to slow	proportional	
	223 - 243	Backwards gobo wheel rotation from slow to fast	proportional	
	244 - 249	Reserved		
	250 - 255	Auto random gobo selection from fast to slow	proportional	
27		Rotating gobo wheel		
		<i>Index - set indexing on channel 29</i>		
	0-13	Open/hole (0=default)	step	
	14-16	LT Follow Spot mode	step	
	17-19	Gobo 1	step	
	20-22	Gobo 2	step	
	23-25	Gobo 3	step	
	26-28	Gobo 4	step	
	29-31	Gobo 5	step	
	32-34	Gobo 6	step	
	35-37	Gobo 7	step	
		<i>Rotation - set rotation on channel 29</i>		
	38-40	LT Follow Spot mode	step	
	41-43	Gobo 1	step	
	44-46	Gobo 2	step	
	47-49	Gobo 3	step	
	50-52	Gobo 4	step	
	53-55	Gobo 5	step	
	56-58	Gobo 6	step	
	59-61	Gobo 7	step	
			<i>Continual positioning</i>	
			<i>Index - set indexing on channel 29</i>	

DMX protocol

Mode/channel	DMX Value	Function	Type of control
1			
	62	Open/hole	proportional
	69	Gobo 1	proportional
	76	Gobo 2	proportional
	83	Gobo 3	proportional
	90	Gobo 4	proportional
	97	Gobo 5	proportional
	104	Gobo 6	proportional
	111	Gobo 7	proportional
	118	Beam reducer	proportional
	125	Open/hole	proportional
		Continual positioning	
		<i>Rotation - set rotation on channel 29</i>	
	126	Open/hole	proportional
	133	Gobo 1	proportional
	140	Gobo 2	proportional
	147	Gobo 3	proportional
	154	Gobo 4	proportional
	161	Gobo 5	proportional
	168	Gobo 6	proportional
	175	Gobo 7	proportional
	182	Beam reducer	proportional
	189	Open/hole	proportional
	190-201	Open/hole	step
	202 - 222	Forwards gobo wheel rotation from fast to slow	proportional
	223 - 243	Backwards gobo wheel rotation from slow to fast	proportional
	244 - 249	Reserved	
	250 - 255	Auto random gobo selection from fast to slow	proportional
28		Rotating gobo wheel - fine positioning	
	0 - 255	Fine positioning (0=default)	proportional
29		Rot. gobo indexing and rotation	
		<i>Gobo indexing - set position on channel 27</i>	
	0 - 255	Gobo indexing (128=default)	proportional
		<i>Gobo rotation - set position on channel 27</i>	
	0	No rotation	step
	1 - 127	Gobo rotation from fast to slow - CW (clockwise)***	proportional
	128	No rotation (128=default)	step
	129 - 255	Gobo rotation from slow to fast - CCW (counterclockwise)***	proportional
30		Rot. gobo indexing/rotation - fine	
	0-255	Fine indexing/rotation (0=default)	proportional
31		Prism 1 (6-facet linear)	
	0 - 19	Open position - hole (0=default)	step
	20 - 73	Prism indexing	step
	74-127	Prism rotation	step
		Prism/gobo macros	
		<i>The following channels are blocked: Prism 1, Prism 1 rotation, Rotating gobo wheel, Rot. Gobo wheel fine positioning, Rot. Gobo indexing and rotation, Rot. Gobo wheel fine rotation.</i>	
	128 - 135	Macro 1	step

DMX protocol

Mode/channel	DMX Value	Function	Type of control
1			
	136 - 143	Macro 2	step
	144 - 151	Macro 3	step
	152 - 159	Macro 4	step
	160 - 167	Macro 5	step
	168 - 175	Macro 6	step
	176 - 183	Macro 7	step
	184 - 191	Macro 8	step
	192 - 199	Macro 9	step
	200 - 207	Macro 10	step
	208 - 215	Macro 11	step
	216 - 223	Macro 12	step
	224 - 231	Macro 13	step
	232 - 239	Macro 14	step
	240 - 247	Macro 15	step
	248 - 255	Macro 16	step
32		Prism 1 indexing/rotation	
		<i>Prism indexing - set position on channel 31</i>	
	0 - 255	Prism 1 indexing	proportional
		<i>Prism rotation - set position on channel 31</i>	
	0	No rotation	step
	1 - 127	Prism rotation from fast to slow - CW (clockwise)***	proportional
	128	No rotation (128=default)	step
	129-255	Prism rotation from slow to fast - CCW (counterclockwise)***	proportional
33		Prism 2 (6-facet circular)	
	0 - 19	Open position - hole (0=default)	step
	20-127	Prism 2 rotation	step
		Prism 2 /gobo macros	
		<i>Rot. gobo wheel, Rot. Gobo wheel fine pos., Rot. Gobo indexing and rotation, Rot. Gobo fine rot.</i>	
	128 - 135	Macro 1	step
	136 - 143	Macro 2	step
	144 - 151	Macro 3	step
	152 - 159	Macro 4	step
	160 - 167	Macro 5	step
	168 - 175	Macro 6	step
	176 - 183	Macro 7	step
	184 - 191	Macro 8	step
	192 - 199	Macro 9	step
	200 - 207	Macro 10	step
	208 - 215	Macro 11	step
	216 - 223	Macro 12	step
	224 - 231	Macro 13	step
	232 - 239	Macro 14	step
	240 - 247	Macro 15	step
	248 - 255	Macro 16	step
34		Prism 2 rotation	
	0	No rotation	step
	1 - 127	Prism rotation from fast to slow - CW (clockwise)***	proportional

DMX protocol

Mode/channel	DMX Value	Function	Type of control
1			
	128	No rotation (128=default)	step
	129-255	Prism rotation from slow to fast - CCW (counterclockwise)***	proportional
35		Frost	
	0	Open (0=default)	step
		Light Frost	
	1-50	Light Frost from 0% to 100%	proportional
	51-53	100% Light Frost	step
	54-63	Pulse closing from slow to fast	proportional
	64-73	Pulse opening from fast to slow	proportional
	74-83	Ramping from fast to slow	proportional
	84-86	Open	step
		Medium Frost	
	87-136	Medium Frost from 0% to 100%	proportional
	137-139	100% Medium Frost	step
	140-149	Pulse closing from slow to fast	proportional
	150-159	Pulse opening from fast to slow	proportional
	160-169	Ramping from fast to slow	proportional
	170-255	Reserved	
36		Iris	
	0	Open (0=default)	step
	1 - 179	From max. diameter to min. diameter	proportional
	180 - 191	Closed	step
		Pulse effects with Iris blackout	
	192 -219	Pulse opening from slow to fast	proportional
	220 - 247	Pulse closing from fast to slow	proportional
	248 - 249	Random pulse opening (fast)	step
	250 - 251	Random pulse opening (slow)	step
	252 - 253	Random pulse closing (fast)	step
	254 - 255	Random pulse closing (slow)	step
37		Iris - fine	
	0 - 255	Fine iris movement (0=default)	proportional
38		Zoom	
	0 - 255	Zoom from max. to min. beam angle (128=default)	proportional
39		Zoom - fine	
	0-255	Fine zooming (0=default)	proportional
40		Focus	
	0 - 255	Continuous adjustment from far to near (128=default)	proportional
41		Focus - fine	
	0- 255	Fine focusing (0=default)	proportional
42		Framing shutters module rotation	
	0-127	Rotation from right (0°) to 60°	proportional
	128	Centre (128=default)	step
	129-255	Rotation from 60° to left (120°)	proportional
43		Framing shutter 1- movement	
	0-255	Movement from Outward to Inward (0=default)	proportional
44		Framing shutter 1- swivelling	
	0-127	Swivelling from -30 degrees towards 0 degrees	proportional
	128	0 degrees (128=default)	step

DMX protocol

Mode/channel	DMX Value	Function	Type of control
1	129-255	Swivelling from 0 degrees to +30 degrees	proportional
45		Framing shutter 2- movement	
	0-255	Movement from Outward to Inward (0=default)	proportional
46		Framing shutter 2- swivelling	
	0-127	Swivelling from -30 degrees towards 0 degrees	proportional
	128	0 degrees (128=default)	step
47	129-255	Swivelling from 0 degrees to +30 degrees	proportional
		Framing shutter 3 movement	
	0-255	Movement from Outward to Inward (0=default)	proportional
48		Framing shutter 3- swivelling	
	0-127	Swivelling from -30 degrees towards 0 degrees	proportional
	128	0 degrees (128=default)	step
49	129-255	Swivelling from 0 degrees to +30 degrees	proportional
		Framing shutter 4 movement	
	0-255	Movement from Outward to Inward (0=default)	proportional
50		Framing shutter 4- swivelling	
	0-127	Swivelling from -30 degrees towards 0 degrees	proportional
	128	0 degrees (128=default)	step
51	129-255	Swivelling from 0 degrees to +30 degrees	proportional
		Shutter/ strobe	
	0 - 31	Shutter closed	step
	32 - 63	Shutter open (32=default)	step
	64 - 95	Strobe-effect from slow to fast	proportional
	96 - 127	Shutter open	step
	128 - 143	Opening pulse in sequences from slow to fast	proportional
	144 - 159	Closing pulse in sequences from fast to slow	proportional
	160 - 191	Shutter open	step
	192 - 223	Random strobe-effect from slow to fast	proportional
	224 - 255	Shutter open	step
52		Dimmer intensity	
	0 - 255	Dimmer intensity from 0% to 100% (0=default)	proportional
53		Dimmer intensity - fine	
	0 - 255	Fine dimming (0=default)	proportional
*** CW and CCW rotation is determined from the perspective of the fixture's mounting point, looking along the projected beam's direction			
Copyright © 2024-2026 Robe Lighting s.r.o. - All rights reserved			
All Specifications subject to change without notice			

Robin iEsprite® LTL WB/ Robin iEsprite® LTL FS - Colours on Virtual Colour Wheel						
Colour name	Col. Wheel 1 DMX	Col. Wheel 2 DMX	Cyan DMX	Magenta DMX	Yellow DMX	CTO DMX
Filter 4 (Medium Bastard Amber)	0	0	0	134	136	169
Filter 10 (Medium Yellow)	0	0	0	12	186	246
Filter 19 (Fire)	156	0	0	188	0	0
Filter 26 (Bright Red)	130	0	0	43	0	255
Filter 58 (Lavender)	0	0	20	189	125	0
Filter 68 (Sky Blue)	0	154	152	119	0	0
Filter 71 (Tokyo Blue)	144	0	0	0	0	0
Filter 79 (Just Blue)	0	154	149	128	0	0
Filter 88 (Lime Green)	0	168	132	4	208	0
Filter 90 (Dark Yellow Green)	0	0	217	0	213	0
Filter 100 (Spring Yellow)	0	0	0	0	188	135
Filter 101 (Yellow)	0	0	0	151	206	0
Filter 102 (Light Amber)	0	0	0	146	175	0
Filter 103 (Straw)	0	0	0	140	168	0
Filter 104 (Deep Amber)	0	0	0	167	220	0
Filter 105 (Orange)	0	0	0	190	241	0
Filter 106 (Primary Red)	154	0	0	194	0	0
Filter 111 (Dark Pink)	0	0	0	184	178	0
Filter 115 (Peacock Blue)	0	0	250	0	171	0
Filter 116 (Medium Blue-Green)	0	0	236	0	178	0
Filter 117 (Steel Blue)	0	0	176	83	149	0
Filter 118 (Light Blue)	0	0	221	0	150	0
Filter 119 (Dark Blue)	0	0	245	116	18	0
Filter 120 (Deep Blue)	0	154	255	0	0	85
Filter 121 (Filter Green)	0	142	140	0	196	0
Filter 128 (Bright Pink)	0	0	69	227	192	0
Filter 131 (Marine Blue)	0	0	208	26	132	0
Filter 132 (Medium Blue)	0	0	236	0	75	0
Filter 134 (Golden Amber)	0	0	0	184	255	0
Filter 135 (Deep Golden Amber)	0	0	0	207	255	0
Filter 136 (Pale Lavender)	0	0	72	183	136	0
Filter 137 (Special Lavender)	0	0	30	155	118	0
Filter 138 (Pale Green)	0	0	119	81	181	0
Filter 139 (Primary Green)	0	0	255	0	232	0
Filter 141 (Bright Blue)	0	0	235	82	131	0
Filter 147 (Apricot)	0	0	0	174	208	0
Filter 148 (Bright Rose)	0	0	0	214	210	0
Filter 152 (Pale Gold)	0	0	0	174	185	0
Filter 154 (Pale Rose)	0	0	26	172	168	0
Filter 157 (Pink)	0	0	14	207	211	0
Filter 158 (Deep Orange)	0	0	0	205	236	0
Filter 162 (Bastard Amber)	0	0	0	160	179	0
Filter 164 (Flame Red)	0	0	0	243	248	0
Filter 165 (Daylight Blue)	0	0	209	0	63	0
Filter 169 (Lilac Tint)	0	0	0	178	148	0

Colour name	Col. Wheel 1 DMX	Col. Wheel 2 DMX	Cyan DMX	Magenta DMX	Yellow DMX	CTO DMX
Filter 170 (Deep Lavender)	0	0	81	179	127	0
Filter 172 (Lagoon Blue)	0	0	222	37	135	0
Filter 179 (Chrome Orange)	0	0	0	175	248	0
Filter 180 (Dark Lavender)	0	0	156	170	0	0
Filter 181 (Congo Blue)	0	0	176	201	0	20
Filter 197 (Alice Blue)	0	154	222	0	0	48
Filter 201 (Full C.T. Blue)	0	0	180	0	103	41
Filter 202 (Half C.T. Blue)	0	0	166	0	70	75
Filter 203 (Quarter C.T. Blue)	0	0	134	17	113	0
Filter 204 (Full C.T. Orange)	0	0	0	182	247	0
Filter 205 (Half C.T. Orange)	0	0	38	163	185	0
Filter 206 (Quarter C.T. Orange)	0	0	0	158	151	0
Filter 247 (Filter Minus Green)	0	0	0	173	134	0
Filter 248 (Half Minus Green)	0	0	0	129	107	0
Filter 281 (Three Quarter C.T. Blue)	0	0	176	0	108	53
Filter 285 (Three Quarter C.T. Orange)	0	0	0	168	232	0
Filter 352 (Glacier Blue)	0	0	207	0	101	20
Filter 353 (Lighter Blue)	0	0	218	0	139	0
Filter 715 (Cabana Blue)	0	154	250	0	0	63
Filter 778 (Millennium Gold)	0	0	0	199	243	0
Filter 793 (Vanity Fair)	0	0	16	216	153	0